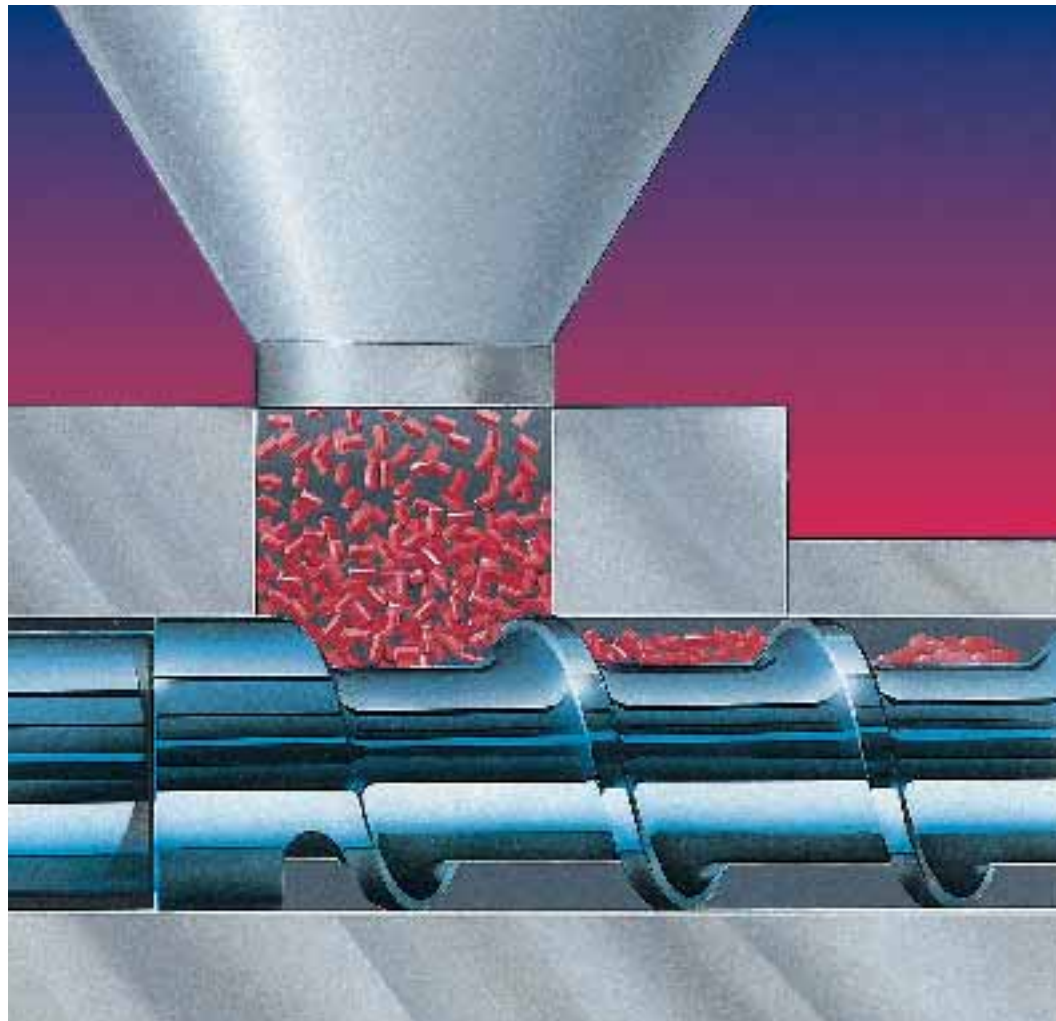


Celanex[®], Vandar[®], Impet[®] and Riteflex[®] Thermoplastic Polyesters

**Processing and
Troubleshooting
Guide (PE-6)**



Typical Injection Molding Parameters

Molding Parameter	Celanex®*	Vandar®**	Impet®	Riteflex®
Mold Temperature °C (°F)	38 - 121 (100 - 250)	38 - 121 (100 - 250)	110 - 121 (230 - 250)	24 - 93 (75 - 200)
Melt Temperature °C (°F)	227 - 260 (440 - 500)	238 - 282 (460 - 540)	271 - 299 (520 - 570)	171 - 266 (340 - 510)
Screw Speed, rpm	60 - 125	60 - 125	60 - 125	60 - 125
Back Pressure, psi	0 - 50	0 - 100	0 - 25	0 - 100
Injection Speed	Fast	Medium to Fast	Medium to Fast	Fast
Injection Pressure	Low to Medium	Low to High	As Needed	Low to Medium
Cushion, Inches	0.125	0.125	0.125	0.125 - 0.250
Barrel Settings °C (°F)				
Feed Zone	232 - 249 (450 - 480)	232 - 254 (450 - 490)	260 - 271 (500 - 520)	154 - 243 (310 - 470)
Center Zone	238 - 254 (460 - 490)	238 - 260 (460 - 500)	271 - 277 (520 - 530)	171 - 249 (340 - 480)
Front Zone	243 - 260 (470 - 500)	243 - 266 (470 - 510)	277 - 282 (530 - 540)	171 - 254 (340 - 490)
Nozzle	249 - 260 (480 - 500)	249 - 271 (480 - 520)	277 - 288 (530 - 550)	171 - 260 (340 - 500)

* For parameters specific to Celanex "16" series grades, refer to Table 3.2, Chapter 3.

** For parameters specific to Vandar Grades 6000, AB100, AB875, and 9114 see Table 3.3, Chapter 3.

Typical Extrusion Processing Parameters

Parameters	Celanex®	Vandar®	Impet®	Riteflex®
Barrel Settings °C (°F)				
Zone 1	232 - 271 (450 - 520)	232 - 271 (450 - 520)	254 - 271 (490 - 520)	182 - 199 (360 - 390)
Zone 2	232 - 271 (450 - 520)	232 - 271 (450 - 520)	254 - 271 (490 - 520)	188 - 204 (370 - 400)
Zone 3	232 - 271 (450 - 520)	232 - 282 (450 - 540)	260 - 282 (500 - 540)	188 - 204 (370 - 400)
Zone 4	238 - 271 (460 - 520)	238 - 288 (460 - 550)	266 - 288 (510 - 550)	193 - 210 (380 - 410)
Zone 5	238 - 271 (460 - 520)	238 - 288 (460 - 550)	266 - 288 (510 - 550)	193 - 210 (380 - 410)
Adapter °C (°F)	238 - 271 (460 - 520)	238 - 288 (460 - 550)	266 - 288 (510 - 550)	193 - 210 (380 - 410)
Die °C (°F)	238 - 271 (460 - 520)	238 - 293 (460 - 560)	271 - 293 (520 - 560)	199 - 221 (390 - 430)
Melt Temperature °C (°F)	238 - 271 (460 - 520)	238 - 293 (460 - 560)	271 - 293 (520 - 560)	199 - 221 (390 - 430)

Foreword

This processing and troubleshooting guide (PE-6) contains updated information on injection molding and extrusion parameters for the Ticona Polyester products, and was written to help processors, tool builders, and part designers take full advantage of their excellent material properties and processing characteristics. They comprise the following:

- Celanex® Thermoplastic Polyesters
- Vandar® Thermoplastic Alloys
- Impet® Thermoplastic Polyesters
- Riteflex® Thermoplastic Polyester Elastomers

For more information on design and material characteristics of polyesters, consult the following Ticona publications which can be obtained by calling Product Information Services at 1-800-833-4882.

- Designing With Plastic: The Fundamentals, Design Manual (TDM-1)
- Celanex® Thermoplastic Polyester – Short Term Properties (CX-4)
- Celanex® “16” Series Polyesters
- Vandar® Thermoplastic Alloys – Short Term Properties (VN-4)
- Impet® Thermoplastic Polyester – Short Term Properties (IP-4)
- Riteflex® Thermoplastic Polyester Elastomer – Short Term Properties (RF-4)

Material Safety Data Sheets (MSDS) for specific grades of Celanex®, Vandar®, Impet®, and Riteflex® polyesters have been developed by Ticona. MSDS sheets provide valuable safety, health, and environmental information. **Before processing these products, read and thoroughly understand the appropriate MSDS.** They may be obtained by calling Customer Services at 1-800-526-4960.

Chapter 1. Overview

General	1-1
Celanex® Thermoplastic Polyester	1-1
Vandar® Thermoplastic Alloys	1-3
Impet® Thermoplastic Polyester	1-3
Riteflex® Thermoplastic Polyester Elastomer	1-4

Chapter 2. Mold Design, Equipment Selection and Preprocessing

Mold Design	2-1
Conventional Runners	2-1
Gates	2-1
Venting	2-4
Mold Cooling	2-4
Melt Flow	2-4
Mold Shrinkage	2-4
Runnerless Molds	2-6
Annealing	2-7
Molding Process	2-8
Plastication	2-8
Injection	2-8
Molding Equipment	2-9
Screw Design	2-9
Nozzle	2-10
Nonreturn Valves	2-10
Clamping Systems	2-10
Mold Construction	2-10
Resin Storage	2-11
Use of Regrind	2-11
Drying Resin	2-11
Drying Equipment	2-11
Drying Process	2-13
General Drying Guidelines	2-13

Chapter 3. Processing – Injection Molding

General	3-1
Safety and Health Information	3-1
Celanex® Polyester Molding Conditions	3-2
Drying Requirements	3-2
Melt Temperature	3-2
Mold Temperature	3-2
Injection and Holding Pressure	3-2
Injection Speed	3-2
Cycle Time	3-2
Back Pressure and Screw Speed	3-3
Startup	3-3
Shutdown	3-3

Chapter 3. Processing – Injection Molding (Continued)

Vandar® Alloy Molding Conditions	3-4
Drying Requirements	3-4
Melt Temperature	3-4
Mold Temperature	3-4
Injection and Holding Pressure	3-4
Injection Speed	3-5
Cycle Time	3-5
Back Pressure and Screw Speed	3-5
Startup	3-5
Shutdown	3-5
Impet® Polyester Molding Conditions	3-6
Drying Requirements	3-6
Mold Temperature	3-6
Riteflex® Polyester Molding Conditions	3-7
Drying Requirements	3-7
Mold Temperature	3-7
Injection and Holding Pressure	3-7
Injection Speed	3-7
Screw Speed and Cushion	3-7
Shutdown	3-7

Chapter 4. Troubleshooting – Injection Molding

Introduction	4-1
Troubleshooting Guide	4-1

Chapter 5. Processing – Extrusion

General	5-1
Safety and Health Information	5-1
Drying Requirements	5-1
Equipment	5-1
Extruder Barrel	5-1
Screw Design	5-1
Breaker Plate and Screens	5-2
Dies	5-2
Processing Procedures	5-2
Startup	5-2
Purging and Shutdown	5-2
Wire Coating	5-4
Cooling Trough	5-4
Tube Extrusion	5-5
Vacuum Tank	5-5
Sheet Extrusion	5-6
Polishing Roll Stand	5-6

Chapter 6. Troubleshooting – Extrusion

Introduction	6-1
Troubleshooting Guide	6-1

List of Tables

Table 1.1	Celanex Grades and Processing Methods	1-2
Table 1.2	Vandar Grades and Processing Methods	1-3
Table 1.3	Impet Grades and Processing Methods	1-3
Table 1.4	Riteflex Grades and Processing Methods	1-4
Table 2.1	Runner Size Recommendations	2-1
Table 2.2A	Size Recommendations, Rectangular Edge Gate for Celanex®, Impet®, and Vandar® (Higher Modulus Grades) Polyesters	2-4
Table 2.2B	Size Recommendations, Direct Gate (From Secondary Sprue in 3-Plate Mold) for Celanex®, Impet®, and Vandar® (Higher Modulus Grades) Polyesters	2-4
Table 2.3	Shrinkage – Celanex® Polyesters	2-5
Table 2.4	Shrinkage – Vandar® Alloys	2-6
Table 2.5	Shrinkage – Impet® Polyesters	2-6
Table 2.6	Shrinkage – Riteflex® Polyester Elastomers	2-6
Table 2.7	Drying Guidelines	2-13
Table 3.1	Typical Injection Molding Parameters	3-1
Table 3.2	Molding Conditions for Celanex® Polyester	3-2
Table 3.3	Molding Conditions for Vandar® Alloys	3-4
Table 3.4	Molding Conditions for Impet® Polyester	3-6
Table 3.5	Molding Conditions for Riteflex® Polyester Elastomer	3-7
Table 4.1	Troubleshooting Guide – Injection Molding	4-1
Table 5.1	Barrel Length-to-Diameter Ratios	5-1
Table 5.2	Typical Lengths of Feed, Transition, and Metering Zones	5-2
Table 5.3	Typical Extrusion Temperature Ranges for Celanex® Polyester	5-3
Table 5.4	Typical Extrusion Temperature Ranges for Vandar® Alloys	5-3
Table 5.5	Typical Extrusion Temperature Ranges for Impet® Polyester	5-3
Table 5.6	Typical Extrusion Temperature Ranges for Riteflex® Polyester Elastomer	5-3
Table 6.1	Troubleshooting Guide – Extrusion	6-1

List of Figures

Figure 2.1 Balanced Runner and Cavity Layout	2-1
Figure 2.2A Various Gate Types Used in Injection Molds	2-2
Figure 2.2B Various Gate Types Used in Injection Molds	2-3
Figure 2.3 Gate and Mold Design Affect Part Strength	2-3
Figure 2.4 Flow vs. Wall Thickness for Celanex 3300	2-4
Figure 2.5 Molding Sequence, Single Stage Reciprocating Screw Injection Molding Machine	2-8
Figure 2.6 Single Stage Reciprocating Screw Injection Molding Machine	2-9
Figure 2.7 Recommended Metering Screw	2-9
Figure 2.8 Check Ring Nonreturn Valve Used on Reciprocating Screw Injection Molding Machines	2-10
Figure 2.9 Internal Ball Check Nonreturn Valve Used on Reciprocating Screw Injection Molding Machines	2-10
Figure 2.10 Hopper Dryer Unit	2-12
Figure 5.1 Typical Screw Design	5-1
Figure 5.2 Polyester in Wire Coating	5-4
Figure 5.3 Polyester in Tube Extrusion	5-5
Figure 5.4 Polyester in Sheet Extrusion	5-6

Overview

General

Chapter 1 contains an overview of the four polyester product groups available from the Ticona Corporation: Celanex® Thermoplastic Polyesters, Vandar® Thermoplastic Alloys, Impet® Thermoplastic Polyesters, and Riteflex® Thermoplastic Polyester Elastomers. Brief descriptions of each product group are followed by a table which identifies the various grades within the product group and processing methods best suited for each grade.

Celanex® Thermoplastic Polyesters

Polybutylene terephthalate (PBT), the polymer from which Celanex products are compounded, is semi-crystalline and is formed by the polycondensation of 1,4 – butanediol and dimethyl terephthalate. The base polymer can be compounded with various additives, fillers, and reinforcing agents. Because of their composition and degree of crystallinity, these products exhibit a unique combination of properties that includes:

- High strength, rigidity, and toughness.
- Low creep (even at elevated temperatures).
- Outstanding resistance to high temperatures.
- Minimal moisture absorption.
- Exceptional dimensional stability.
- Resistance to a wide range of chemicals, oils, greases, and solvents.
- Excellent electrical properties.

Celanex PBT also offers outstanding processing characteristics including:

- Fast cycles.
- Absence of volatiles during processing.
- The significant advantage of accepting high levels of reprocessed product (up to 50% for certain grades).

Rigidity, heat resistance, creep resistance, and electrical properties are among the superior performance characteristics that differentiate Celanex thermoplastic polyester from other engineering thermoplastics.

Celanex resins are supplied in unreinforced grades and in grades formulated with glass-fiber and minerals. Some products are categorized as flame retardant (UL94 V-0); others are general purpose.

Table 1.1 lists grades of Celanex® Thermoplastic Polyesters and recommended processing methods.

Table 1.1 Celanex® Grades and Processing Methods

Type of Material and Grade	Processing Methods	
	Injection Molding	Extrusion
Unreinforced		
1300	•	
1400A	•	
1600A	•	•
1602Z	•	•
1700A	•	•
2000	•	
2000-2	•	
2000-3	•	
2000-2K	•	
2001	•	•
2002	•	•
2002-2	•	•
2002-3	•	•
2003	•	
2003-2	•	
2003-3	•	
2004-2	•	
2008	•	•
2012-2	•	•
2016	•	•
Glass Reinforced, General Purpose		
1462Z	•	
3200	•	
3200-2	•	
3201	•	
3201-2	•	
3202-2	•	
3300	•	
3300-2	•	
3400-2	•	
Glass Reinforced, Flame Retardant		
3112-2	•	•
3116	•	•
3210-2	•	
3216	•	
3310-2	•	
3316	•	

Table 1.1 Celanex® Grades and Processing Methods (Continued)

Type of Material and Grade	Processing Methods	
	Injection Molding	Extrusion
High Impact		
1632Z	•	
1642Z	•	
1662Z	•	
4202	•	
4300	•	
4302	•	
4305	•	
306	•	
Good Surface Finish		
5200-2	•	
5300-2	•	
7862Z	•	
Low Warp, General Purpose		
J235	•	
J600	•	
LW2333R	•	
LW6443R	•	
LW6362R	•	
LW7345R	•	
6400-2	•	
6406	•	
6407	•	
6500	•	
Low Warp, Flame Retardant		
7304	•	
7305	•	
316	•	
7700-2	•	

Vandar® Thermoplastic Alloys

Vandar products are thermoplastic polyester alloys possessing:

- Outstanding ductility and stiffness combined with the excellent chemical and environmental resistance properties of polyesters.
- High impact strength at ambient and low temperatures.

The unreinforced and higher flexibility grades possess high impact with a flexibility between that of thermoplastics and elastomers. Unfilled Vandar 8000 has a flammability rating of UL94 V-0 as low as 0.85 mm (0.033 in.) part thickness. The remainder of the Vandar products are rated UL94 HB.

Vandar alloys are also available in grades formulated with glass fiber and minerals. Filled grades improve modulus and strength while maintaining excellent toughness.

Table 1.2 lists grades of Vandar alloys and recommended processing methods.

Table 1.2 Vandar Grades and Processing Methods

Type of Material and Grade	Processing Methods	
	Injection Molding	Extrusion
Unreinforced General Purpose		
2100	•	•
2500	•	•
4602Z	•	•
6000	•	•
Unreinforced and Flame Retardant		
8000	•	•
Glass Reinforced		
4361	•	
4612R	•	
4632Z	•	
4662Z	•	
AB875	•	
Unreinforced Higher Flexural Modulus		
8929	•	•
9114, 9116	•	•
AB100	•	
Mineral Reinforced		
2122	•	•

Impet® Thermoplastic Polyesters

Impet products are thermoplastic polyesters made with up to 100% post consumer recycled polyethylene terephthalate (PET). They possess outstanding physical properties and superior thermal and chemical resistance.

Impet polyesters are ideal for high performance applications that require toughness, rigidity, exceptional dimensional stability and excellent electrical properties, and have flame retardance ratings of UL94 HB.

The Impet grades are reinforced with glass fibers or with combinations of mineral/glass fibers.

Table 1.3 lists grades of Impet polyesters and recommended processing methods.

Table 1.3 Impet Grades and Processing Methods

Type of Material and Grade	Processing Methods	
	Injection Molding	Extrusion
Glass Reinforced		
320R	•	•
330R	•	
340R	•	
Glass/Mineral Reinforced		
610R	•	•
630R	•	
830R	•	

Riteflex® Thermoplastic Polyester Elastomer

Riteflex products are a family of copolyester polymers, which combine many desirable features of thermoset rubbers with the processing ease of engineering plastics. These products are tough, tear resistant, resist flex fatigue, and perform over a broad temperature span.

Riteflex elastomers are resistant to many chemicals including acids and bases, common solvents, oils, and greases. They are also abrasion resistant. The harder versions exhibit enhanced heat and chemical resistance while the softer materials possess good low temperature mechanical properties.

Table 1.4 lists grades of Riteflex elastomers and recommended processing methods.

Table 1.4 Riteflex Grades and Processing Methods

Type of Material and Grade	Processing Methods	
	Injection Molding	Extrusion
635	•	
640	•	•
647	•	
655	•	•
663	•	
677	•	•

* The last 2 digits denote the Shore D hardness, e.g. Grade 640 has a Shore D hardness of 40.

Mold Design, Equipment Selection and Preprocessing

Mold Design

The Ticona family of engineering thermoplastic polyester resins may be successfully molded in conventional two- and three-plate molds, stack molds, and in a wide variety of hot runner and insulated runner molds.

Conventional Runners

Full round runners are recommended, and trapezoidal are second best. Rectangular or half round runners may also be used, but they are less efficient. Suggested sizes for full round runners are provided in Table 2.1.

Table 2.1 Runner Size Recommendation

Part Thickness (Inches)	Runner Length (Inches)	Min. Runner Diameter (Inches)
0.020 - 0.060	Up to 2	0.0625
0.020 - 0.060	Over 2	0.125
0.060 - 0.150	Up to 4	0.125
0.060 - 0.150	Over 4	0.1875
0.150 - 0.250	Up to 4	0.250
0.150 - 0.250	Over 4	0.3125

Generous radii should be provided in the runner system where the sprue joins the runner.

On multiple-cavity molds with primary and secondary runners, the primary runner should extend beyond the intersection of the secondary runner in order to provide a cold slug well for the runner flow front. This length should be at least equal to the basic runner diameter, **D** (See Figure 2.1).

Runner length should be kept at a minimum. Parts requiring close dimensional control in multi-cavity molds should have balanced runner systems. Close tolerance parts should not be designed into family mold layouts.

Gates

Various types of gates used in injection molds are shown in Figures 2.2A, 2.2B, and 2.3.

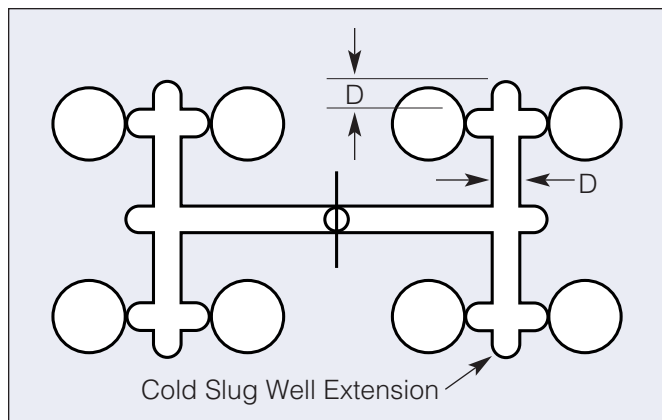


Figure 2.1 Balanced Runner and Cavity Layout

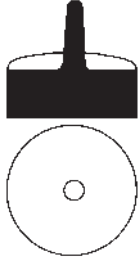
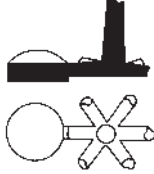
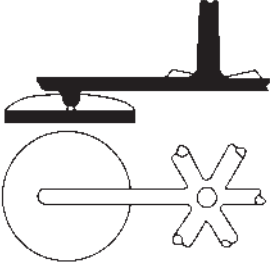
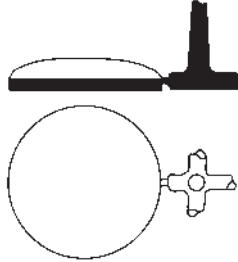
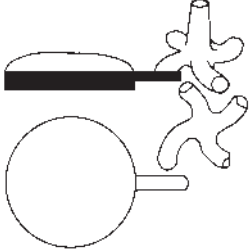

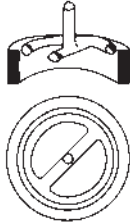
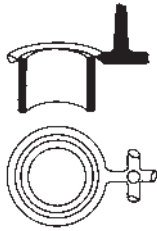
 <p>SPRUE: A simple design for single cavity molds and symmetry on circular shapes. Suitable for thick sections.</p>	 <p>SIDE or EDGE: A simple design for multicavity molds. Suitable for medium and thick sections.</p>
 <p>PIN (3 plate tool): Used to minimize finishing where edge gating is undesirable and for automatic degating. Only suitable for thin sections.</p>	 <p>RESTRICTED or PIN: Provides simple degating and finishing. Only suitable for thin sections.</p>
 <p>TAB: Used to stop jetting when other means are not available and when a restricted gate is desired. Also enables area of greatest strain to be removed from the molding.</p>	 <p>DIAPHRAGM: Used for single cavity concentric moldings of ring shape with medium or small internal diameter.</p>
 <p>INTERNAL RING: Similar to diaphragm gate. Used for molds with large internal diameters or to reduce (sprue/runner) to molding ratio.</p>	 <p>EXTERNAL RING: Used for multicavity concentric moldings of ring shape or where diaphragm gate cannot be used.</p>

Figure 2.2A Various Gate Types Used in Injection Molds

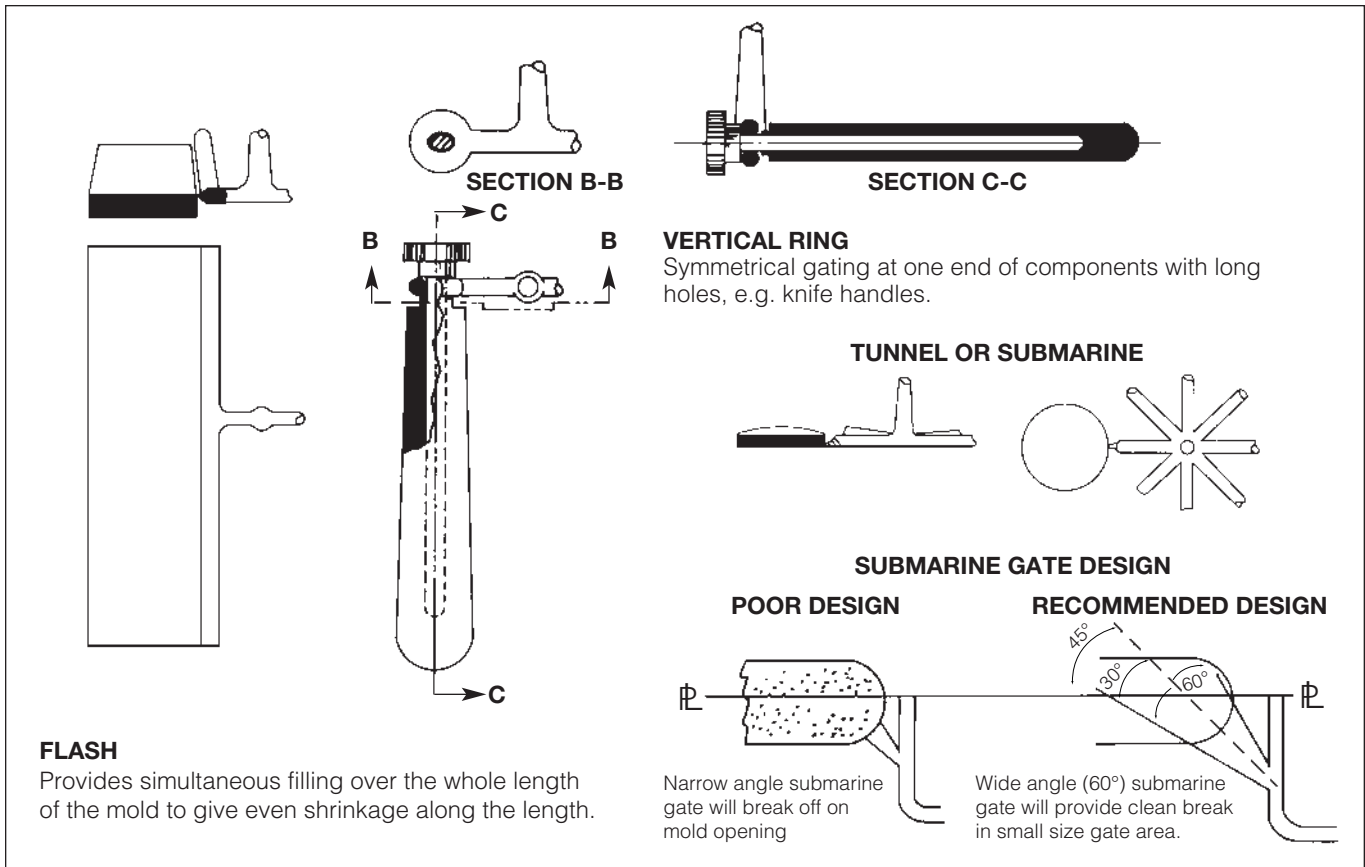


Figure 2.2B Various Gate Types Used in Injection Molds

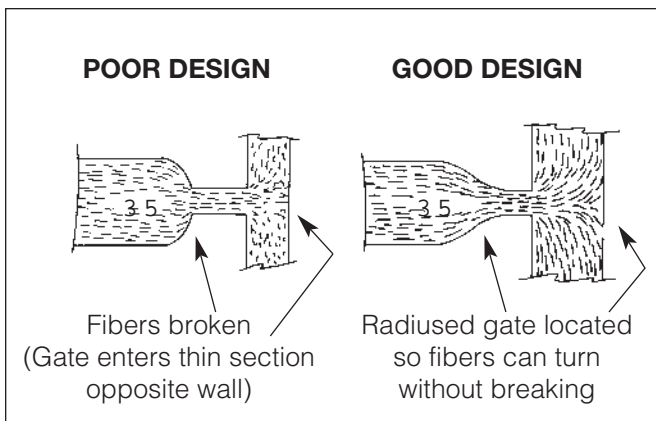


Figure 2.3 Gate and Mold Design Affect Part Strength

Gate location should be selected carefully to minimize possible part distortion or adverse effects on part dimensions due to anisotropic shrinkage (see "Mold Shrinkage", page 2-4). For best results, the gate should be located so as to achieve balanced flow in all directions, and minimum flow length from the gate to the extremities of the part. Where this is not possible, the gate should be located so that the flow direction is along the axis of the most critical dimension, since the mold shrinkage is considerably less in the direction of flow, particularly in glass fiber reinforced grades.

To minimize breakage and reduction in length of the glass fibers in the reinforced grades, it is desirable to gate the part in a thick rather than a thin-walled section, and to incorporate radii where the runner joins the gate. This is illustrated in Figure 2.3.

Gate size recommendations, keyed to part thickness, are given in Tables 2.2A and 2.2B.

Table 2.2A Size Recommendations, Rectangular Edge Gate for Celanex®, Impet® and Vandar® (Higher modulus grades) Polyesters

Part Thickness (Inches)	Gate Dimensions (Inches)		
	Depth	Width	Land Length
Less than 0.030	To 0.020	To 0.040	0.040
0.030 - 0.090	0.020 - 0.060	0.030 - 0.090	0.040
0.090 - 0.125	0.060 - 0.085	0.090 - 0.130	0.040
0.125 - 0.250	0.085 - 0.165	0.130 - 0.250	0.040

Table 2.2B Size Recommendations, Direct Gate (From Secondary Sprue in 3-Plate Mold) for Celanex®, Impet® and Vandar® (Higher modulus grades) Polyesters

Part Thickness (Inches)	Gate Diameter (Inches)	Land Length (Inches)
Less than 0.125	0.030 - 0.050	0.040
0.125 - 0.250	0.040 - 0.120	0.040

Venting

Because of the rapid mold filling qualities of polyester resins, adequate mold venting is necessary to preclude the burning of material from compressed air. Vents should be located at the edge of the cavity furthest from the gate. Suggested vent size is 0.001 inch deep x 0.125 inch wide. These vents should be cut in the mold parting line from the edge of the cavity to the outside of the mold. Vents should be deepened, beginning 0.125 inch from the cavity. Venting is particularly critical at knit-lines and the last segment of the cavity to fill.

Mold Cooling

Productivity and part quality are directly influenced by proper mold cooling. Polyester resins, when cooled below the melting point, solidify rapidly with the potential for achieving fast molding cycles. This requires a well designed mold cooling system that provides a uniform mold temperature with cooling channels near thicker part sections, and (when possible) directly in mold inserts and cores. For proper mold temperature control, a separate temperature controller for core and cavity is recommended. Temperature controls capable of reaching 121°C (250°F) will provide sufficient flexibility for most molding applications.

Melt Flow

Polyester resin is extremely fluid in the melt state and therefore flows well in a mold. However, rapid crystallization imposes limitations on how far the resin will flow in filling a mold. Among the process variables that influence flow are melt temperature, mold temperature, injection pressure and composition. Wall thickness also influences resin flow. Thicker sections allow for larger flow than thinner sections. Figure 2.4 shows the influence of wall thickness on flow.

Mold Shrinkage

As with all other crystalline resins, the mold shrinkage of polyester is anisotropic. Shrinkage in the direction of material flow is always less than in the transverse direction.

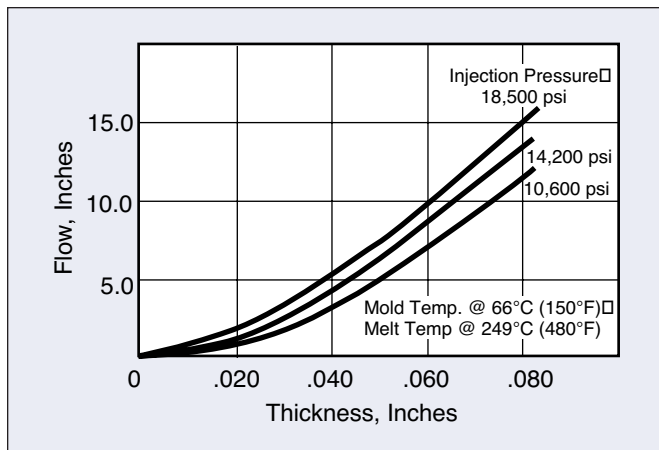


Figure 2.4 Flow vs. Wall Thickness for Celanex 3300

Variables that significantly affect part shrinkage during molding include:

- Melt/mold temperatures.
- Injection pressure.
- Flow direction, gate/runner design and size.
- Part or wall thickness and size.
- Presence (low shrinkage) or absence (high shrinkage) of fibrous reinforcements.

To accurately design molds, **it is strongly recommended that the mold/design engineer determine shrinkage of the actual part by using prototype tooling before making the final tool.**

Measurements of the material to be used should be made on prototype parts having the same geometry as the final part. Shrinkage measurements on a spectrum of molding conditions should be included to define the range of variations. Note that changes in gating, weld lines, mold cooling, etc. may change shrinkage of the final part versus the prototype part.

Contact your local Ticona representative or call Product Information Services at 1-800-833-4882 for further information on part shrinkage before molds are sized to final dimensions.

Note: In designing molds, extreme care must be exercised when using shrinkage data from ISO or ASTM test specimens. These data should be used only as a guide for plastic material property comparisons. (See Tables 2.3 - 2.6).

**Table 2.3 Celanex Grade Shrinkage
Celanex® Polyester**

Grades	In/In Flow Direction	(%)
Unreinforced	0.018 - 0.020	1.8 - 2.0
Unreinforced Flame Retardant 2016	0.025 - 0.030	2.5 - 3.0
Glass Reinforced, General Purpose 3200, 3201	0.005 - 0.007	0.5 - 0.7
3202	0.004 - 0.006	0.4 - 0.6
1462Z, 3300, 3400	0.003 - 0.005	0.3 - 0.5
Glass Reinforced, Flame Retardant 3112	0.005 - 0.007	0.5 - 0.7
3116	0.010 - 0.014	1.0 - 1.4
3210, 3216	0.004 - 0.006	0.4 - 0.6
3310	0.003 - 0.005	0.3 - 0.5
3316	0.003 - 0.005	0.3 - 0.5
High Impact 1632Z, 4202	0.003 - 0.007	0.3 - 0.7
4300, 4302	0.003 - 0.005	0.3 - 0.5
Good Surface Finish 5200	0.004 - 0.006	0.4 - 0.6
5300, 7862Z	0.003 - 0.005	0.3 - 0.5
Low Warp, General Purpose 6407, 6500	0.002 - 0.005	0.2 - 0.5
J235	0.004 - 0.006	0.4 - 0.6
J600, LW6443R	0.004 - 0.006	0.4 - 0.6
6400, 6406	0.004 - 0.006	0.4 - 0.6
Low Warp, Flame Retardant 7305, 7316	0.003 - 0.005	0.3 - 0.5
7304, 7700	0.005 - 0.007	0.5 - 0.7
7716	0.002 - 0.005	0.2 - 0.5

* Data obtained from laboratory test specimens.

Table 2.4 Shrinkage – Vandar® Alloys

Grades	In/In Flow Direction	(%)
Unreinforced, General Purpose 2100, 2500, 4602Z	0.017 - 0.022	1.7 - 2.2
6000	0.005 - 0.009	0.5 - 0.9
Unreinforced ,Flame Retardant 8000	0.025 - 0.028	2.5 - 2.8
Glass Reinforced 4361	0.002 - 0.005	0.2 - 0.5
4612R	0.006 - 0.008	0.6 - 0.8
4632Z	0.004 - 0.006	0.4 - 0.6
4662Z	0.003 - 0.005	0.3 - 0.5
Unreinforced, Higher Flexural Modulus 8929	0.015 - 0.020	1.5 - 2.0
9056, 9114, 9116	0.011 - 0.016	1.1 - 1.6
9500	0.011 - 0.016	1.1 - 1.6
Mineral Reinforced 2122	0.013 - 0.015	1.3 - 1.5

Table 2.5 Shrinkage – Impet® Polyesters

Grades	In/In Flow Direction	(%)
Glass Reinforced 320R	0.004 - 0.0070	0.4 - 0.7
330R	0.001 - 0.0030	0.1 - 0.3
340R	0.001 - 0.0020	0.1 - 0.2
Mineral Filled 610R	0.005 - 0.0080	0.5 - 0.8
630R	0.003 - 0.0050	0.3 - 0.5
830R	0.001 - 0.0030	0.1 - 0.3

Table 2.6 Shrinkage – Riteflex® Polyester Elastomers

Grades	In/In Flow Direction	(%)
640	0.009 - 0.011	0.9 - 1.1
655	0.014 - 0.016	1.4 - 1.6
677	0.018 - 0.022	1.8 - 2.2

* Data obtained from laboratory test specimens, 0.125 inch thick.

Runnerless Molds

Continuing increases in the costs of labor, materials, etc. have been a driving force for cost reductions in processing and the production of moldings of better quality at lower prices. This, in turn, has sparked a new interest in automation including the use of runnerless molds. The increased demand for such molds has resulted in a rapid expansion of runnerless molding technology and a proliferation of commercially available runnerless molds.

Runnerless molds, as the name implies, are molds in which no sprues and runners are produced with the parts. The material being molded is kept in a plasticized state all the way from the heating cylinder of the injection molding machine to the gate in the mold cavity and only molded parts are removed from the mold each time the press opens. No sprues or runners are produced, and therefore none need to be reprocessed as in conventional molding. Runnerless molding provides excellent opportunities for material and cost savings, with many additional benefits. Product quality and productivity can be improved, and there is little or no scrap to regrind.

Polyester compounds have been successfully molded in virtually all types of commercially available runnerless molds. As with other thermoplastic resins, runnerless molds should have adequate temperature control and be designed with generously rounded bends in the runner system. Sharp bends in the runner system as well as other areas where resin may hang up and degrade over a period of time of elevated temperatures should be avoided.

For more information on runnerless molding, contact your local Ticona representative or call Product Information Services at 1-800-833-4882.

Annealing

The main purpose of annealing is to stabilize part dimensions by accelerating the effects of stress relaxation.

Few applications require annealing. Polyester resin parts properly designed and molded in a hot, 93 - 121°C (200 - 250°F) mold have sufficient dimensional stability for all but the most exacting requirements.

However, if resin parts are to be used at higher temperature (over 93°C or 200°F), and dimensional stability is required, then annealing is recommended. Annealing relieves residual stresses in moldings, causing most "stress relaxation" shrinkage to occur in the annealing operation rather than in service.

Caution: In some cases, stress relief through annealing can lead to part warpage, especially if shrinkage is nonuniform. Multiple test parts should be produced initially to determine if this problem arises.

Polyester resin parts may be annealed in an air circulating oven capable of maintaining uniform temperature throughout its interior. Recommended annealing temperature is 204±2.8°C (400 ±5°F).

Annealing time depends primarily on part thickness, part geometry and processing conditions. It is good practice to determine minimum annealing time and then add a "safety factor". This can be done by placing several parts in the oven and removing them one at a time at predetermined intervals. After a cooling time of at least 24 hours, the parts are measured, and the point at which the dimensions show no further change is the minimum annealing time.

A "rule of thumb" annealing time for most polyester resin parts is 1-3 hours in air, depending on part thickness. It is suggested that the minimum annealing time be determined for a specific part as described above.

Typical shrinkage encountered in glass fiber reinforced grades during annealing is up to 0.002 inch/inch in the flow direction and 0.003 inch/inch in the transverse direction. This is in addition to the mold shrinkages shown in Tables 2.3 - 2.6.

Molding Process

Because molding is so crucial to producing high quality parts, it is essential to understand the process and to select equipment which ensures consistency and efficiency. Figure 2.5 illustrates the plastication (A) and injection (B) sequences of a single stage, reciprocating, screw injection molding machine.

Plastication

The hopper feeds dried resin into the barrel. The feed section of the screw conveys the resin forward. Resin is melted by the heat of the barrel and mechanical shear of the transition zone. Molten plastic is then

pressurized and conveyed through the metering zone forming a melt pool in front of the screw. As the melt pool accumulates a sufficient shot size, it forces the screw to retract.

Injection

The screw moves forward seating the check ring which forces the molten polymer through the sprue, runners, and gates into the cavities of the mold. The part conforms to the shape of the mold cavities and the cooled mold helps to solidify the plastic into a solid form. The mold opens and the part is ejected, usually with the aid of ejection pins.

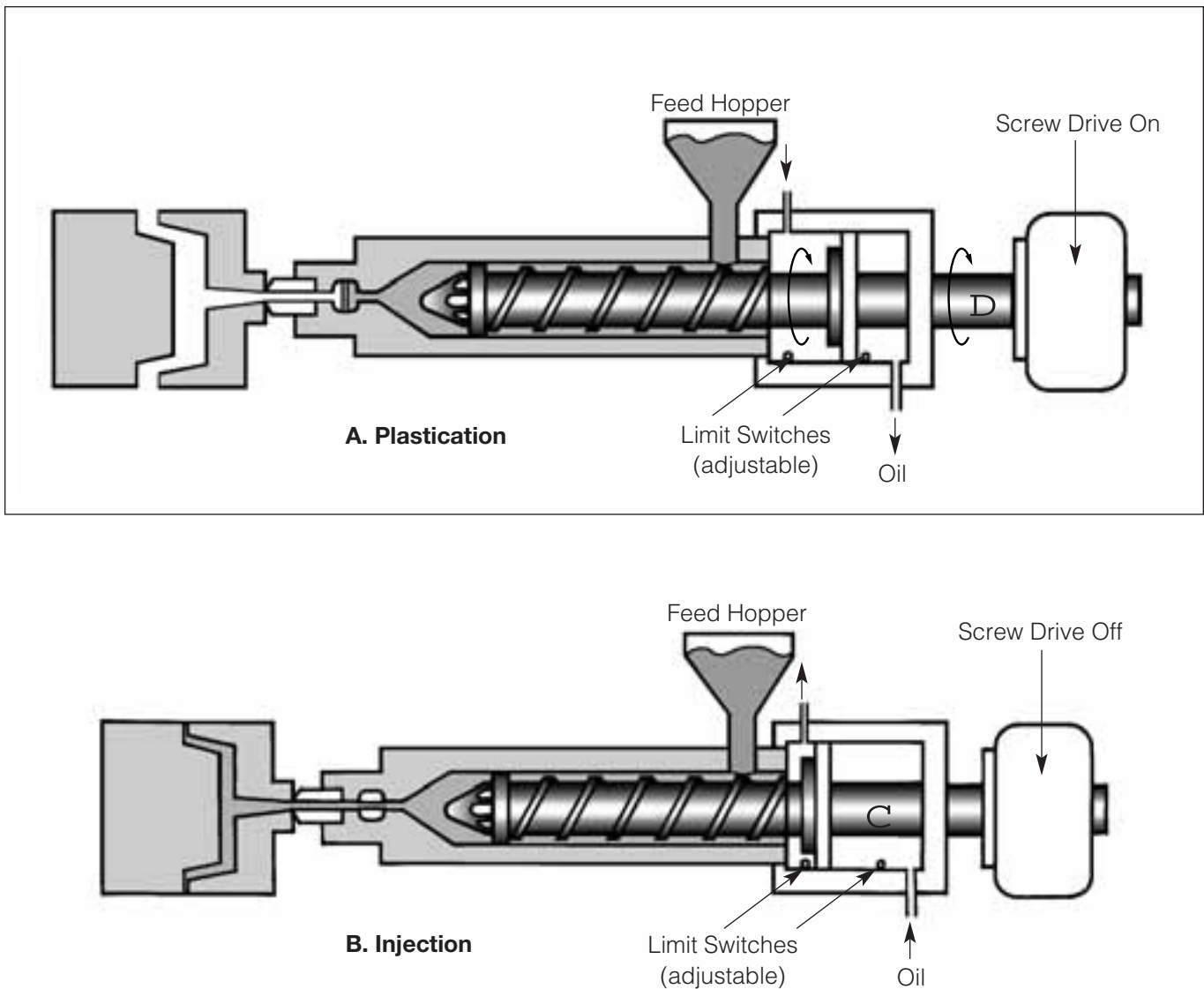


Figure 2.5 Molding Sequence, Single Stage Reciprocating Screw Injection Molding Machine

Molding Equipment

Polyester resins can be processed without difficulty in different types of screw injection molding machines. For reference purposes, a typical single stage reciprocating screw injection molding machine is shown in Figure 2.6.

For best results, machines should be selected so that the shot weight is in the 50% range of rated machine capacity. This minimizes residence time and prevents excessive thermal degradation.

Screw Design

The metering type screw generally recommended for polyester resins is shown in Figure 2.7. The bottom portion of this illustration shows the three major sections of the screw – the feed zone, transition zone,

and metering zone. The feed and metering zones both maintain constant root diameters while the transition zone employs an involuted taper.

Since polyester materials are fast cycling, a machine should have a high plasticating capability to achieve optimum cycle times. Some general guidelines are:

- Metering zone: 3 - 4 flights
- Zone distribution:
 - 50% feed zone
 - 25% transition zone
 - 25% metering zone
- L/D ratio: 16:1 to 24:1
- Compression ratio: 3:1 to 4:1

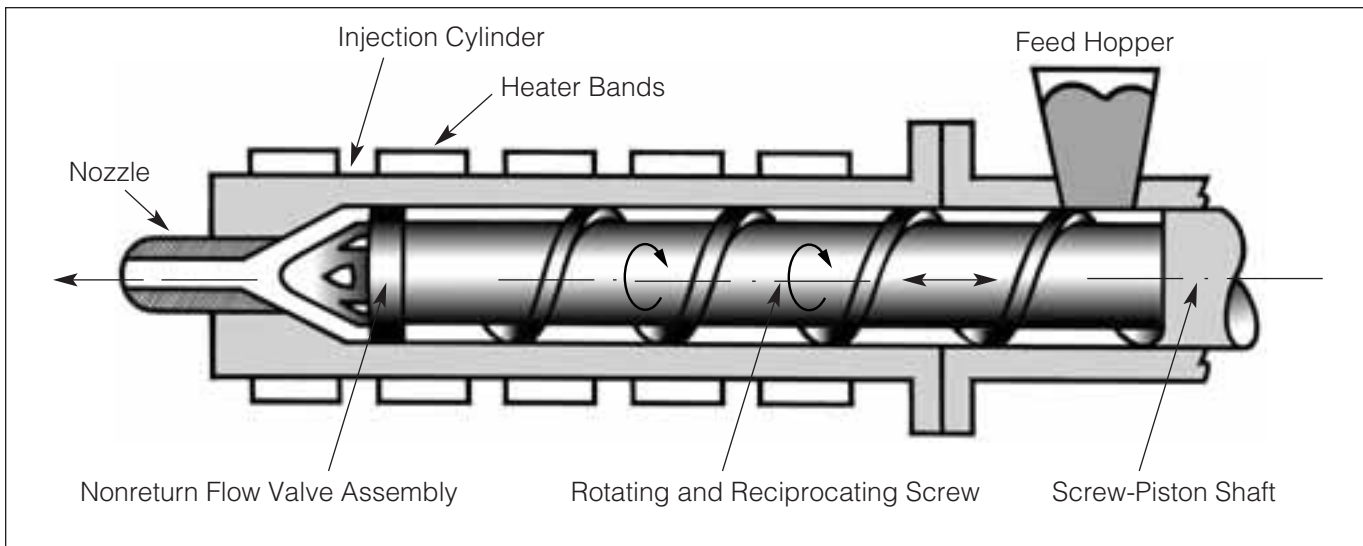


Figure 2.6 Single Stage Reciprocating Screw Injection Molding Machine

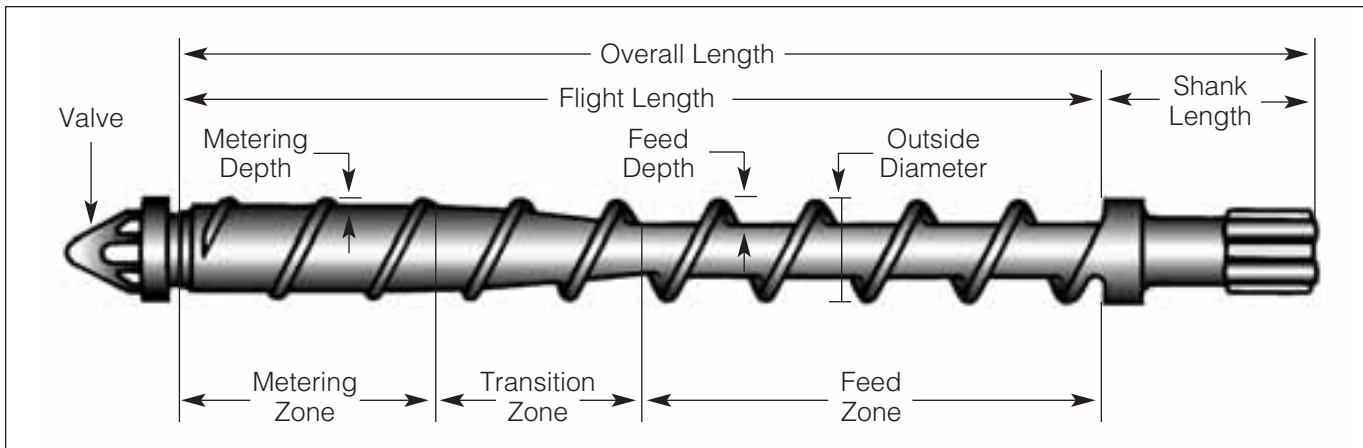


Figure 2.7 Recommended Metering Screw

If you have any problems or questions regarding proper screw design, contact Product Information Services at 1-800-833-4882 or the manufacturer of your equipment.

Nozzle

A simple, free flow type nozzle with an independent heater band temperature controller is recommended. Free flowing nozzles require melt compression (suck-back) control on the machine.

Nonreturn Valves

Figures 2.8 and 2.9 show the check ring and internal ball check nonreturn valves used on reciprocating

screw injection molding machines. These valves are shown in both the plastication and injection cycles of the molding process.

Clamping Systems

The clamp keeps the mold closed by either a toggle mechanism or by a hydraulic cylinder. Polyester resins can be processed on either type. The clamp force should be 3 to 4 tons per square inch of projected surface area (including runners).

Mold Construction

The recommended mold steel hardness for all polyester products is H 13.

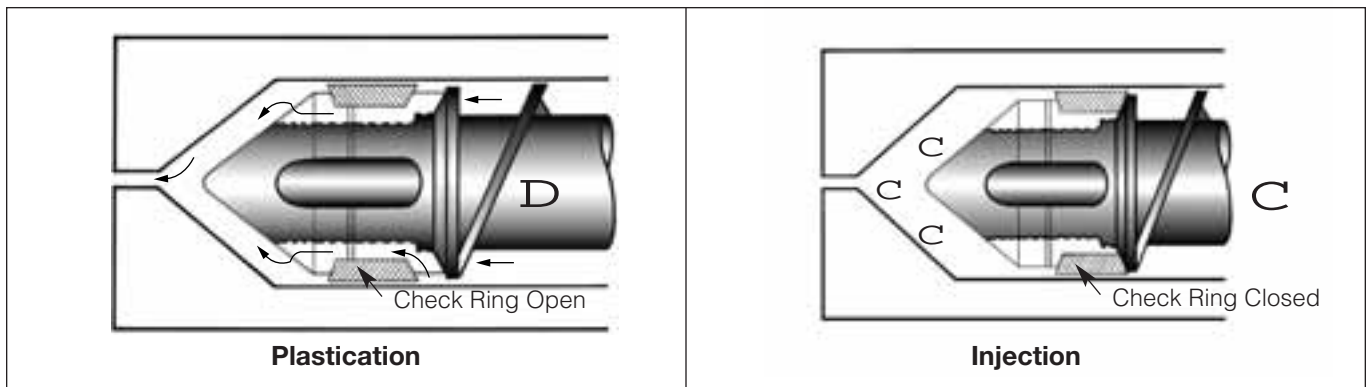


Figure 2.8 Check Ring Nonreturn Valve Used on Reciprocating Screw Injection Molding Machines

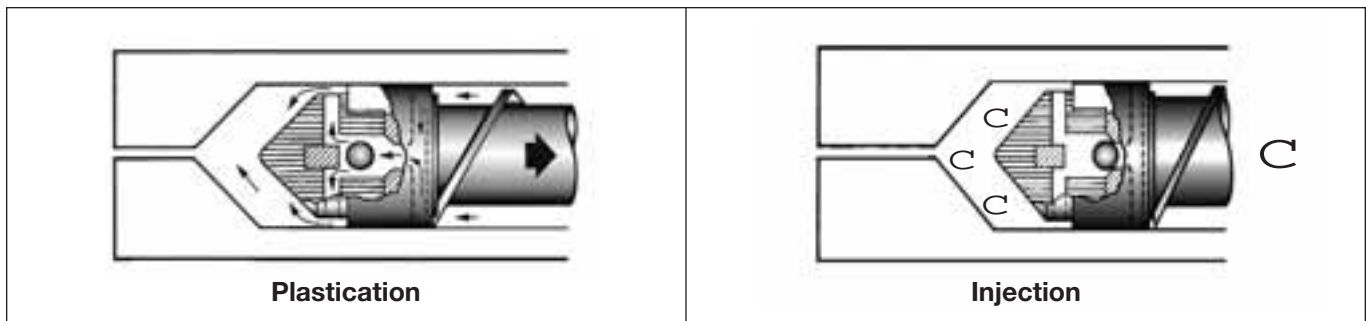


Figure 2.9 Internal Ball Check Nonreturn Valve Used on Reciprocating Screw Injection Molding Machines

Resin Storage

During storage, avoid climatic temperature and humidity extremes which can lead to excessive moisture adsorption on the surface of virgin and regrind material. Avoiding these extremes are particularly important when storing regrind because of its very large surface area. In any case, virgin and regrind materials must be dried to recommended moisture levels before molding begins.

Use of Regrind

Properly dried polyester compounds have excellent thermal stability during molding. This permits the successful use of regrind in the molding process.

Regrind should be:

- Free of contamination.
- Combined with virgin resin in the ratio of no more than 25% regrind to 75% virgin resin (see note below for exceptions).
- Dried together with the virgin resin before molding.

Note: Celanex® thermoplastic polyester grades 2016, 3116, 3126, 3216, 3226, and 3316 have been approved by Underwriters Labs for regrind usage up to 50%. The UL94 V-0 rating is retained with part thicknesses as small as 0.75 mm (0.030 inch).

Drying Resins

It is extremely important to thoroughly dry virgin and regrind material and minimize exposure to ambient air before molding parts. High moisture levels can:

- Cause processing problems.
- Create surface imperfections including voids.
- Degrade the material causing significant reduction of mechanical properties.

Drying Equipment

Because of the importance of properly dried polymer, we strongly recommend using dehumidifying hopper dryers such as the unit shown in Figure 2.10. Hot air ovens should not be used because:

- Trays filled to a depth of more than 1 to 1.5 inches can cause inadequate drying.
- Drying time is extended because of poor heat transfer.
- Different materials being dried in the same oven can be inadvertently mixed causing contamination.

If hot air ovens are absolutely necessary, they should be used following the above precautions, as long as the recommended moisture level is reached. (See Table 2.7 on pg 2-13).



1. Vacuum Loader

2. Drying Hopper

3. Filter

4. Process Air Blower

5. Desiccant Cartridge

6. Dehumidified Air Reheater

7. Regeneration Blower

8. Regeneration Heater

Figure 2.10 Hopper Dryer Unit (Reprinted with permission of Novatec™, Inc. Baltimore MD)

Drying Process

Figure 2.10 shows a typical hopper dryer unit. A vacuum loader (1) drops resin into the insulated drying hopper (2) on demand. Heated, dehumidified air enters the drying hopper, penetrating the resin and carrying moisture vapor up to the return line outlet. Moisture-laden air passes through a filter (3) to remove fines or very small particles before the air re-enters the desiccant cartridge. **This filter must be kept clean!**

To save energy, the heated air should be recirculated. The process air blower (4) forces moisture-laden air through on-stream desiccant cartridges (5) where moisture is trapped. The dehumidified air is then reheated (6) and delivered back to the drying hopper.

While the desiccant cartridge is on stream removing moisture, another cartridge is being regenerated. Separate regeneration blowers (7) and heaters (8) are used for that purpose.

General Drying Guidelines

To produce acceptable moisture levels when drying virgin or regrind material in a dehumidifying hopper drier, use the guidelines provided in Table 2.7.

For drying polyester materials, dew points should be maintained between -30°C and -40°C.

If polymer is to be dried overnight, temperatures can be reduced to 102°C (215°F) for Celanex®, Impet® and most Vandar® polyesters. For the very flexible Vandar® and Riteflex® polyesters, use 93°C (200°F) for overnight drying. **For best results, these moisture levels must be achieved and maintained while processing all polyester products.**

Table 2.7 Drying Guidelines (Use dehumidifying dryer)

Product Type	Temperature	Drying Time	Moisture Level
Celanex	121°C (250°F)	4 hours	less than 0.02%
Vandar	107°C (225°F)	3 to 4 hours	less than 0.02%
Vandar 9114*	68°C (155°F)	4 hours or overnight	less than 0.02%
Impet	135°C (275°F)	4 hours	less than 0.01%
Riteflex	107°C (225°F)	4 hours	less than 0.05%

* To successfully dry Vandar 9114, it is critical that the dew point be -30°C or lower.

Processing – Injection Molding

General

For all polyester products, the molder must control processing parameters carefully to produce high quality molded parts. The quality of the finished part depends as much on proper processing as it does on part design.

Chapter 3 contains basic guidelines for injection molding Celanex® thermoplastic polyester, Vandar® thermoplastic alloy, Impet® thermoplastic polyester, and Riteflex® thermoplastic polyester elastomer.

Typical injection molding parameters for each product group are summarized in Table 3.1. This is followed by more specific molding information on the various grades within each product group.

When molding an unfamiliar grade or if problems arise during processing that cannot be corrected using the troubleshooting guide in Chapter 4, contact your local Ticona representative or call Product Information Services at 1-800-833-4882.

Safety and Health Information

Before starting the injection molding process, obtain and read the appropriate polyester Material Safety Data Sheet (MSDS) for detailed safety and health information. They may be obtained by calling Customer Services at 1-800-526-4960.

Use process controls, work practices, and protective measures described in the MSDS sheets to control workplace exposure to dust, volatiles, etc.

Table 3.1 Typical Injection Molding Parameters

Molding Parameter	Celanex*	Vandar**	Impet	Riteflex
Mold Temperature °C (°F)	38 - 121 (100 - 250)	38 - 121 (100 - 250)	110 - 121 (230 - 250)	24 - 93 (75 - 200)
Melt Temperature °C (°F)	227 - 260 (440 - 500)	238 - 282 (460 - 540)	271 - 299 (520 - 570)	171 - 266 (340 - 510)
Screw Speed, rpm	60 - 125	60 - 125	60 - 125	60 - 125
Back Pressure, psi	0 - 50	0 - 100	0 - 25	0 - 100
Injection Speed	fast	medium to fast	medium to fast	fast
Injection Pressure	low to medium	low to high	as needed	low to medium
Cushion, Inches	0.125	0.125	0.125	0.125 - 0.250
Barrel Settings °C (°F)				
Feed Zone	232 - 249 (450 - 480)	232 - 254 (450 - 490)	260 - 271 (500 - 520)	154 - 243 (310 - 470)
Center Zone	238 - 254 (460 - 490)	238 - 260 (460 - 500)	271 - 277 (520 - 530)	171 - 249 (340 - 480)
Front Zone	243 - 260 (470 - 500)	243 - 266 (470 - 510)	277 - 282 (530 - 540)	171 - 254 (340 - 490)
Nozzle	249 - 260 (480 - 500)	249 - 271 (480 - 520)	277 - 288 (530 - 550)	171 - 260 (340 - 500)

* For parameters specific to Celanex "16" series grades, see Table 3.2 (page 3-2).

** For parameters specific to Vandar Grade 6000, AB100, AB875 and 9114, see Table 3.3 (page 3-4).

Table 3.2 Molding Conditions for Celanex Polyester

Molding Parameter	Celanex Grades	
	3116, 3216, 3316	All Other Celanex Grades
Mold Temperature °C (°F)	66 - 93 (150 - 200)	38 - 121 (100 - 250)
Melt Temperature °C (°F)	238 - 249 (460 - 480)	238 - 260 (460 - 500)
Screw Speed, rpm	60 - 125	60 - 125
Back Pressure, psi	0 - 25	0 - 50
Injection Speed	fast	fast
Injection Pressure, psi	as needed to fill mold	low to medium
Cushion, Inches	0.125	0.125
Barrel Settings °C (°F)		
Feed Zone	238 - 249 (460 - 480)	232 - 249 (450 - 480)
Center Zone	243 - 254 (470 - 490)	238 - 254 (460 - 490)
Front Zone	243 - 254 (470 - 490)	243 - 260 (470 - 500)
Nozzle	249 - 260 (480 - 500)	249 - 260 (480 - 500)

Celanex® Thermoplastic Polyester Molding Conditions

Table 3.2 contains recommended molding conditions for all grades of Celanex thermoplastic polyester.

Drying Requirements

Celanex resins should be dried to a moisture level equal to or less than 0.02% before injection molding. Refer to pages 2-11 through 2-13 for more information on drying.

Melt Temperature

The melt temperature should be 238 - 260°C (460 - 500°F). Avoid melt temperatures in excess of 271°C (520°F). Provide adequate ventilation in the molding area. Also, keep barrel residence time to a minimum for optimum part properties.

Mold Temperature

Mold temperatures for Celanex polyesters are generally in the 38 - 121°C (100 - 250°F) range. For unfilled resins, use 38 - 66°C (100 - 150°F). For glass reinforced resins, use 66 - 93°C (150 - 200°F).

Unlike most other glass reinforced resins, Celanex polyester yields a smooth, glossy finish even when molded in a relatively cold mold. Higher mold temperatures are used to obtain the ultimate in surface gloss and uniformity, maximize crystallinity, and minimize mold and post-mold part shrinkage.

Low mold temperatures are sometimes used to help prevent sink or warpage.

Injection and Holding Pressure

Because of its ease of flow, Celanex polyesters require only moderate injection pressures (typically in the range of 50 - 75% of machine maximum).

Holding pressures are typically in the range of 60 - 80% of the injection pressures. Since Celanex polyester crystallizes rapidly, holding pressures (and holding time) are dependent on part thickness. Very thin-walled parts may require only moderate holding pressure while thick-section parts may require high holding pressure and long holding times.

Injection Speed

Fast fill speed is desirable because Celanex polyester solidifies very rapidly once it enters the mold cavity. In some cases, reduced fill speed can help cure warpage problems induced by orientation of the glass fibers in the material.

Cycle Time

Because Celanex polyester solidifies rapidly, cycle times can be extremely short. Plunger forward times need only be long enough to deliver the molten charge to the mold and hold the material under pressure until the gate freezes.

The part should be sufficiently set up so that when it is ejected any impact does not cause dents or any other distortions. Consequently, overall cycle time is a function of part size and wall thickness. Generally, cycles for Celanex polyester molding vary from as little as 5 seconds for small thin-walled parts, to 40 - 45 seconds for large thick-walled parts. Cycle times over 45 seconds are encountered only in rare instances where molds must be opened/closed slowly due to special coring, or where inserts must be loaded into the mold.

Back Pressure and Screw Speed

Use low back pressure and minimum screw speed when molding glass fiber reinforced Celanex polyester in a screw machine. High back pressures and high screw speeds tend to reduce the length of the glass fibers in the material, causing a reduction in physical properties. Generally, screw speeds should be 25 - 50 rpm. Back pressure should be less than 50 psi.

Startup

Before using Celanex polyesters, purge the machine to remove any other type of plastic previously run. Polymers suitable for purging are low or high density polyethylene, polypropylene, and polystyrene. For parts requiring subsequent painting or adhesive application, use low molecular weight PBT (such as Celanex 1400) to purge the machine.

When the cylinder is completely free of the material used for purging, raise cylinder temperatures to 232 - 243°C (450 - 470°F) before feeding Celanex polyester into the machine. After several shots to clear residual foreign polymer, set the desired molding temperatures and start the regular molding on cycle.

Shutdown

For brief shutdown periods (10 - 15 minutes):

1. Lower material temperature to 232 - 238°C (450 - 460°F).
2. Purge the machine periodically, preferably on cycle, to prevent excessive residence time in the cylinder.

For longer shutdown periods:

1. Remove the Celanex material from the barrel.
2. Turn cylinder heaters off with the nozzle maintained at molding temperature.
3. Purge the machine until the material temperature is no higher than 232°C (450°F). Then, shut down the machine.

When shutting down a screw machine, leave the screw in the forward position. If a mass of molten material is left in front of the screw at shutdown, restarting the machine will be delayed until the solidified slug of material (in front of the screw) is remelted.

Vandar® Thermoplastic Alloy Molding Conditions

Table 3.3 contains recommended molding conditions for all grades of Vandar alloys.

Drying Requirements

Vandar alloys should be dried to a moisture level equal to or less than 0.02% before injection molding. Refer to pages 2-11 through 2-13 for more information on drying.

Melt Temperature

For unreinforced grades 6000, 8929, 9056, and 9116, preferred melt temperatures are:

- 260 - 282°C (500 - 540°F) for grade 6000. Do not exceed 293°C (560°F).
- 238 - 266°C (460 - 510°F) for grades 8929, 9056, and 9116. Do not exceed 271°C (520°F).
- For other grades of Vandar alloys see Table 3.3.

Mold Temperature

To maximize impact strength of parts made of Vandar alloys, use mold temperatures below 49°C (120°F).

Mold temperatures for glass filled grades can be higher; up to 93°C (200°F).

Injection and Holding Pressure

Because of ease of flow, grades 8929, 9056, and 9116 require only moderate injection pressures (typically in the range of 50 - 75% of machine maximum). Unreinforced grades (2100, 2500, 4602Z, 6000) and glass filled grades (4316, 4612R, 4632Z, 4662Z) require higher injection pressures.

Holding pressures are typically in the range of 60 - 80% of the injection pressures. Since Vandar alloys crystallize rapidly, holding pressures (and holding time) are dependent on part thickness. Very thin-walled parts may require only moderate holding pressure while thick-section parts may require high holding pressure and long holding times.

To maximize toughness of parts molded of Vandar alloys, avoid overpacking the material.

Table 3.3 Molding Conditions for Vandar® Alloys

Molding Parameter	Vandar Grades				
	AB100	9114**	AB875	6000	All Other Grades
Mold Temperature °C (°F)	21-52 (70-125)	29-52 (85-125)	21-52 (70-125)	38-121 (100-250)	38-121 (100-250)
Melt Temperature °C (°F)	199-210 (390-410)	218-227 (425-440)	188-216 (370-420)	260-282 (500-540)	238-266 (450-510)
Screw Speed, rpm	to match cycle			60-125	60-125
Back Pressure, psi	0-50			0-100	0-100
Injection Speed	Slow, Continuous			medium to fast	fast
Injection Pressure, psi	Start with short shots, increase until fill and add 200 psi			medium to high	medium to high*
Cushion, Inches	0.125-0.250			0.125	0.125
Barrel Settings °C (°F)					
Feed Zone	199 (390)	204 (400)	177-199 (350-390)	243-254 (470-490)	232-243 (450-470)
Center Zone	204 (400)	210 (410)	185-207 (365-405)	249-260 (480-500)	238-249 (460-480)
Front Zone	210 (410)	216 (420)	191-213 (375-415)	254-266 (490-510)	243-254 (470-490)
Nozzle	210 (410)	216 (420)	193-216 (380-420)	260-271 (500-520)	249-260 (480-500)

* Vandar grades 8929 and 9116 require moderate injection pressure (50-75% of machine capacity).

** Vandar 9114 may require a reverse barrel profile.

Injection Speed

Fast fill speed is desirable for the higher modulus Vandar alloys because they solidify very rapidly once they enter the mold cavity. In some cases, reduced fill speed can help cure warpage problems induced by orientation of the glass fibers in the material. For specific recommendations see Table 3.3.

Cycle Time

Because Vandar alloys solidify rapidly, cycle times can be extremely short. Plunger forward time need only be long enough to deliver the molten charge to the mold and hold the material under pressure until the gate freezes.

The part should be sufficiently set up so that when it is ejected any impact does not cause dents or any other distortions. Consequently, overall cycle time is a function of part size and wall thickness. Generally, cycles for Vandar alloy moldings vary from as little as 5 seconds for small thin-walled parts, to 40 - 45 seconds for large thick-walled parts. Cycle times over 45 seconds are encountered only in rare instances where molds must be opened/closed slowly due to special coring, or where inserts must be loaded into the mold.

Back Pressure and Screw Speed

Little back pressure and minimum screw speed should be used in molding glass fiber reinforced Vandar in a screw machine. High back pressures and high screw speeds tend to reduce the length of the glass fibers in the material, causing a reduction in physical properties. Back pressure need only be high enough to compact the molten material in front of the screw as the screw rotates and retracts; the screw speed need only be fast enough to retract the screw before the mold opens. Generally, screw speeds used are in the 25 to 50 rpm range. A normal back pressure level should be under 50 psi.

Startup

Before using Vandar alloys, purge the machine to remove any other type of plastic previously run. Polymers suitable for purging are low or high density polyethylene, polypropylene, and polystyrene. For parts requiring subsequent painting or adhesive application, use low molecular weight PBT (such as Celanex 1400) to purge the machine. When the

cylinder is completely free of the material used for purging, raise cylinder temperatures to the recommended ranges (see Table 3.3) before feeding Vandar alloy into the machine. After several shots to clear residual foreign polymer, set the desired molding temperatures and start the regular molding on cycle.

For initial molding, start with short shots and increase pressure until filled. Then raise the pressure by an additional 100 psi.

Shutdown

For brief shutdown periods (10 -15 minutes):

1. Ensure that the material temperature is no higher than 232°C (450°F) [no higher than 215°C (420°F) for AB100, AB875 and 9118]
2. Purge the machine periodically, preferably on cycle, to prevent excessive residence time in the cylinder.

For longer shutdown periods:

1. Remove the Vandar material from the barrel.
2. Turn cylinder heaters off with the nozzle maintained at molding temperature.
3. Purge the machine until the material temperature is no higher than 232°C (450°F). Then shut down the machine.

When shutting down a screw machine, leave the screw in the forward position. If a mass of molten material is left in front of the screw at shutdown, restarting the machine will be delayed until the solidified slug of material (in front of the screw) is remelted.

Impet® Thermoplastic Polyester Molding Conditions

Table 3.4 contains recommended molding conditions for all grades of Impet polyester.

Table 3.4 Molding Conditions for Impet® Polyesters

Molding Parameter	All Impet Grades
Mold Temperature °C (°F)	110 - 121 (230 - 250)
Melt Temperature °C (°F)	271 - 299 (520 - 570)
Screw Speed, rpm	50 - 75
Back Pressure, psi	0 - 25
Injection Speed	medium to fast
Injection Pressure, psi	as needed
Cushion, Inches	0.125
Barrel Settings °C (°F)	
Feed Zone	260 - 271 (500 - 520)
Center Zone	271 - 277 (520 - 530)
Front Zone	277 - 282 (530 - 540)
Nozzle	277 - 288 (530 - 550)

Drying Requirements

Impet polyester should be dried to moisture levels below 0.01% before injection molding. Refer to pages 2-11 through 2-13 for more information on drying.

It is extremely critical that moisture levels below 0.01% be maintained before injection molding. Therefore, it is recommended that a dehumidifying hopper dryer (as discussed on page 2-12) be used on the injection molding machine.

Mold Temperature

Mold temperatures below 93°C (200°F) may lead to incomplete crystallization and dimensional changes, especially if finished parts are subjected to post-mold elevated temperature use.

Riteflex® Thermoplastic Polyester Elastomer Molding Conditions

Table 3.5 contains recommended molding conditions for all grades of Riteflex polyester elastomer.

Drying Requirements

Riteflex polyester should be dried to a moisture level equal to or less than 0.05% before injection molding. Refer to pages 2-11 through 2-13 for more information on drying.

Mold Temperature

Begin at the lower end of the molding temperature range, using short shots.

Injection and Holding Pressure

Keep injection pressure low when starting the molding cycle; this will produce short shots. Gradually increase pressure by 50 - 100 psi until the cavity fills completely. As complete parts are ejected from the mold, raise injection pressure approximately 100 psi, making sure the material does not flash.

Injection Speed

For all grades of Riteflex polyester elastomers, the injection speed of the machine should be at a medium setting.

Screw Speed and Cushion

Screw speed should be 60 - 125 rpm and the cushion/pad should be 0.125 - 0.250 inch.

Shutdown

When a machine is being shut down from molding Riteflex polyester, the nozzle and barrel heaters should be maintained at the molding temperature. The machine should be first purged with polyethylene or polypropylene. After no more Riteflex polyester elastomer issues from the nozzle, the heating cylinder should be completely purged of Riteflex polyester elastomer and the machine may be shut down.

Table 3.5 Molding Conditions for Riteflex® Polyester Elastomer

Molding Parameter	Riteflex Grades		
	640	655	677
Mold Temperature °C (°F)	24 - 52 (75 - 125)	24 - 52 (75 - 125)	38 - 93 (100 - 200)
Melt Temperature °C (°F)	182 - 204 (360 - 400)	221 - 238 (430 - 460)	238 - 266 (460 - 510)
Screw Speed, rpm	60 - 125	60 - 125	60 - 125
Back Pressure, psi	0 - 50	0 - 50	0 - 100
Injection Speed	fast	fast	fast
Cushion, Inches	0.125 - 0.250	0.125 - 0.250	0.125
Barrel Settings °C (°F)			
Feed Zone	163 - 182 (325 - 360)	199 - 216 (390 - 420)	232 - 243 (450 - 470)
Center Zone	182 - 199 (360 - 390)	216 - 232 (420 - 450)	238 - 249 (460 - 480)
Front Zone	182 - 204 (360 - 400)	216 - 238 (420 - 460)	243 - 254 (470 - 490)
Nozzle	182 - 204 (360 - 400)	216 - 238 (420 - 460)	249 - 260 (480 - 500)

Troubleshooting – Injection Molding

Introduction

Many processing problems are caused by easily corrected conditions such as inadequate resin drying, incorrect temperatures and/or pressures, etc. Often, solutions to these problems can be found by following the recommendations in Table 4.1. Try them in the order in which they are listed under each problem category.

Adjustments should be moderate and the machine should be allowed to line out before any further adjustments are made. Check that the machine is operating within the parameters recommended for the specific grade of resin. For example, stock melt temperature should be confirmed on air shots collected at typical cycle times.

Table 4.1 Troubleshooting Guide – Injection Molding

Problem and Corrective Action	Celanex	Vandar	Impet	Riteflex
Short Shots, Poor Surface Finish				
Increase feed	•	•	•	
Increase injection pressure	•	•	•	•
Use booster and maximum ram speed	•	•		
Decrease cushion	•	•	•	•
Raise cylinder temperature	•	•	•	•
Raise mold temperature	•	•	•	•
Increase overall cycle time	•	•		
Check shot size vs rated machine shot capacity; if shot size exceeds 75% of rated (styrene) shot capacity, move to larger machine	•	•		
Increase size of sprue/runners/gates	•		•	•
Increase injection time			•	
Increase injection speed			•	•
Increase/decrease feed to maintain proper cushion				•
Check cavity vents for blockage				•
Increase booster time				•
Increase screw speed (unfilled grades only)				•
Increase back pressure (unfilled grades only)				•
Use lubricated resin				•
Flashing				
Lower material temperature by: Lowering cylinder temperature	•	•	•	•
Decreasing screw rotational speed			•	•
Lowering back pressure			•	•
Decrease injection pressure	•	•	•	•
Decrease overall cycle time	•	•	•	•
Decrease plunger forward time	•			
Check mold closure for possible obstruction on parting line surface	•	•	•	•

Table 4.1 Troubleshooting Guide – Injection Molding (Continued)

Problem and Corrective Action	Celanex	Vandar	Impet	Riteflex
Flashing (Continued)				
Improve mold venting	•			
Check machine platens for parallelism	•		•	•
Move mold to larger (clamp) press	•		•	
Check parting line of mold for wear				•
Splay Marks				
Dry the material before use	•	•	•	•
Check for contamination such as water or oil leakage into the mold cavity	•	•	•	•
Check for drooling			•	•
Decrease injection speed				•
Raise mold temperature	•	•	•	•
Lower material temperature by: Lowering cylinder temperature				•
Decreasing screw rotational speed				•
Lowering back pressure				•
Lower nozzle temperature				•
Decrease overall cycle time				•
Open the gate(s)				•
Move mold to smaller shot size machine			•	
Discoloration				
Purge heating cylinder	•	•		•
Lower material temperature by: Lowering cylinder temperature	•	•	•	•
Decreasing screw rotational speed				•
Lowering back pressure				•
Lower nozzle temperature	•	•		•
Decrease overall cycle time	•	•	•	•
Check hopper and feed zone for contamination	•	•	•	•
Check cylinder and plunger or screw fit for excessive clearance	•		•	
Provide additional vents in mold	•	•		•
Move mold to machine with smaller shot size (50-75% of capacity for all polyesters)	•	•	•	•
Check ram and feed zone for proper cooling				•
Nozzle Drool				
Lower nozzle temperature	•	•	•	•
Lower material temperature by: Lowering cylinder temperature	•	•	•	•
Decreasing screw rotational speed				•
Lowering back pressure				•
Decrease residual pressure in cylinder by: Reducing plunger forward time and/or back pressure	•	•	•	
Increasing decompress time (if machine has this control)	•	•		•
Decrease overall cycle time			•	

Table 4.1 Troubleshooting Guide – Injection Molding (Continued)

Problem and Corrective Action	Celanex	Vandar	Impet	Riteflex
Nozzle Drool (Continued)				
Reduce back pressure				•
Decrease die open time	•	•		•
Use nozzle with positive shutoff valve	•	•		•
Dry the material before use	•	•	•	•
Use nozzle with smaller orifice			•	•
Use reverse-taper nozzle or nozzle valve			•	•
Nozzle Freeze-off				
Insulate nozzle from mold	•	•	•	
Raise nozzle temperature	•	•	•	•
Decrease cycle time	•		•	•
Increase injection pressure	•			
Decrease injection pressure		•		
Raise mold temperature	•	•	•	•
Use nozzle with larger orifice	•	•	•	•
Use reverse-taper nozzle			•	
Burn Marks				
Decrease injection speed	•	•	•	•
Decrease booster time	•	•		•
Decrease injection pressure	•	•	•	
Improve venting in mold cavity	•	•	•	•
Change gate position and/or increase gate size to alter flow pattern	•		•	•
Sticking in Cavities				
Decrease injection pressure	•	•	•	•
Decrease plunger forward time	•			
Raise mold temperature			•	
Decrease injection time			•	
Decrease injection speed				•
Decrease hold time		•		
Decrease booster time	•			•
Adjust feed for constant cushion	•		•	
Decrease injection hold time				•
Increase mold closed time	•	•	•	•
Lower mold temperature	•	•	•	•
Lower cylinder and nozzle temperature	•	•	•	•
Check mold for undercuts and/or insufficient draft	•	•	•	•
Use proper mold release	•			
Sticking on the Core				
Increase injection pressure				•
Increase booster time				•
Increase injection speed				•
Decrease mold closed time				•
Decrease core temperature				•

Table 4.1 Troubleshooting Guide – Injection Molding (Continued)

Problem and Corrective Action	Celanex	Vandar	Impet	Riteflex
Sticking on the Core (Continued)				
Check mold for undercuts and/or insufficient draft	•	•	•	•
Sticking in Sprue Bushing				
Raise mold temperature			•	
Decrease injection pressure	•	•	•	•
Decrease hold time		•		•
Decrease injection time			•	
Decrease booster time	•	•		
Increase mold closed time	•	•	•	•
Increase mold temperature at sprue bushing	•	•	•	
Raise nozzle temperature	•	•	•	•
Check sizes and alignment of holes in nozzle and sprue bushing (holes in sprue bushing must be larger)	•	•	•	•
Check mold and nozzle design			•	
Provide more effective sprue puller	•	•		•
Weld Lines				
Increase injection pressure	•	•	•	•
Increase injection forward time	•	•	•	•
Increase injection speed				•
Raise mold temperature	•	•	•	•
Raise material temperature by: Raising cylinder temperature				•
Increasing screw rotational speed				•
Increasing back pressure				•
Vent the cavity in the weld area	•	•	•	•
Provide an overflow well adjacent to weld area	•		•	•
Change gate position to alter flow pattern	•		•	•
Unmelted Pellets				
Increase melt temperature	•	•	•	•
Increase back pressure				•
Dry/preheat the resin				•
Use a press with proper screw design (see “Screw Design” on page 2-9 for guidelines)	•	•	•	•
Check to be sure that the nonreturn check valve is working properly to prevent back flow				•
Move the mold to a press with a larger shot capacity				•
Sinks and Voids				
Increase injection pressure	•	•	•	•
Increase injection forward time	•	•		
Increase injection hold time				•
Use booster and maximum ram speed	•	•		•
Increase injection speed			•	
Raise mold temperature (for voids only)	•	•	•	•
Lower mold temperature (for sinks only)	•	•	•	•
Decrease cushion	•		•	•

Table 4.1 Troubleshooting Guide – Injection Molding (Continued)

Problem and Corrective Action	Celanex	Vandar	Impet	Riteflex
Sinks and Voids (Continued)				
Increase feed/maintain proper cushion		•		
Increase size of sprue/runners/gates	•		•	•
Relocate gates closer to heavy sections	•		•	•
Warpage, Part Distortion				
Equalize temperature in both halves of the mold (eliminate hot spots)	•	•	•	•
Check mold for uniform part ejection	•		•	•
Check for proper handling of parts after ejection	•		•	•
Raise tool temperature		•		
Increase gate and runner size		•		
Increase fill speed		•		
Increase injection hold time		•		•
Increase plunger forward time	•			
Increase cooling time			•	
Try increased pressure and decreased pressure	•		•	•
Try higher and lower mold temperature	•		•	
Increase mold closed time	•			•
Lower material temperature by: Lowering cylinder temperature				•
Decreasing screw rotational speed				•
Lowering back pressure				•
Try differential mold temperatures to counteract warp	•	•	•	•
Jig the part and cool uniformly	•		•	•
Check for contamination				•
Brittleness				
Dry the material before use	•	•	•	•
Check for contamination			•	•
Lower melt temperature and/or residence time	•	•	•	
Lower material temperature by: Lowering cylinder temperature	•		•	•
Decreasing screw rotational speed	•		•	•
Lowering back pressure	•		•	•
Lower mold temperature	•			
Raise mold temperature		•	•	
Reduce amount of regrind in feed	•	•	•	•
Delamination				
Raise temperature of mold and/or material			•	•
Check for and eliminate any contamination			•	•
Dry the material before use			•	•
Increase injection speed				•

Table 4.1 Troubleshooting Guide – Injection Molding (Continued)

Problem and Corrective Action	Celanex	Vandar	Impet	Riteflex
Poor Dimensional Control				
Set uniform cycle times	•	•	•	•
Maintain uniform feed and cushion from cycle-to-cycle	•	•	•	•
Eliminate any shot-to-shot machine variation	•		•	
Fill the mold as rapidly as possible	•	•	•	•
Check machine's hydraulic and electrical systems for erratic performance	•	•	•	•
Increase gate size	•	•	•	•
Balance cavities for uniform flow	•		•	
Reduce number of cavities in the mold	•			
Add vents				•
Check for damaged check ring	•			

Processing – Extrusion

General

Chapter 5 contains basic processing guidelines for extruding Celanex® thermoplastic polyesters, Vandar® thermoplastic alloys, Impet® thermoplastic polyesters, and Riteflex® thermoplastic polyester elastomers. When extruding an unfamiliar grade or if problems arise during processing that cannot be corrected using the troubleshooting guide in Chapter 6, contact your local Ticona representative or call Product Information Services at 1-800-833-4882.

Safety and Health Information

Before starting the extrusion process, obtain and read the appropriate polyester Material Safety Data Sheet (MSDS) for detailed safety and health information. They may be obtained by calling Customer Services at 1-800-526-4960.

Use process controls, work practices, and protective measures described in the MSDS sheets to control workplace exposure to dust, volatiles, etc.

Drying Requirements

Celanex, Vandar, Impet, and Riteflex polyesters must be dried to proper moisture levels before extruding. Refer to pages 2-11 through 2-13 for more information on drying.

It is extremely critical that moisture levels below 0.01% be maintained before extruding Impet polyester. Therefore, it is recommended that a dehumidifying hopper dryer (as discussed on page 2-13) be used on the extruding machine. For drying polyesters, dewpoints should be maintained between -30°C and -40°C.

Equipment

For maximum resistance to abrasion and corrosion, extruder screws, breaker plates, screens, adapters, and dies should all be made of corrosion-resistant metals.

Extruder Barrel

Standard extruders, having barrel length-to-diameter ratios equal to or greater than those shown in Table 5.1, are recommended for processing polyesters. Higher L/D ratios provide a more homogeneous melt and higher output rate for a given extruder size.

Screw Design

Screw designs should have a compression ratio between 3:1 and 4:1 (the ratio between the feed zone channel depth and the metering zone channel depth). As shown in Figure 5.1, the feed zone screw depth should be approximately 0.400 inch deep, while the metering zone screw depth should gradually reduce to approximately 0.100 inch.

Table 5.1 Barrel Length-to-Diameter Ratios

Product	L/D Ratios
Celanex	30:1
Vandar	30:1
Impet	30:1
Riteflex	20:1

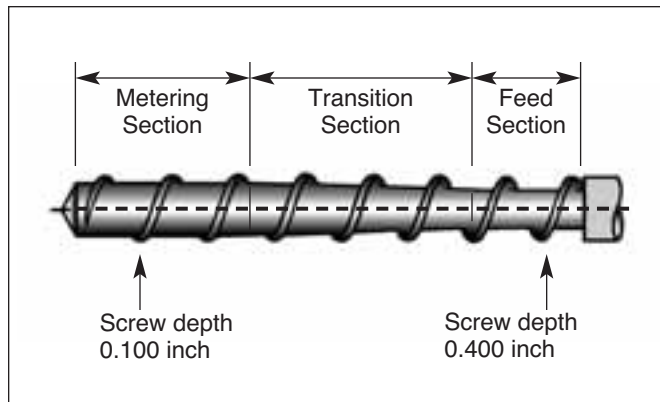


Figure 5.1 Typical Screw Design

Recommended lengths of the feed, transition, and metering zones (each representing a percentage of the total screw length) are shown in Table 5.2.

Table 5.2 Typical Lengths of Feed, Transition and Metering Zones

Product	Zone Distribution (%)		
	Feed	Transition	Metering
Celanex	33	33	33
Vandar	33	33	33
Impet	33	33	33
Riteflex	25	25	50

Feed zone length should comprise at least 25% of the total screw length. A long and gradual transition section of at least 25% is also recommended, since sharp or short transition sections can cause high barrel pressures and higher melt temperatures due to high shear (especially at higher speeds).

Length of the metering zone and the screw depth are critical in maintaining optimum control of melt temperature and output consistency. Too long or shallow a metering zone increases the melt temperature due to shear, while short and deep metering zones can result in pressure fluctuations (surging) and nonuniform output.

A typical polyethylene type screw design meets the requirements for processing polyesters. Screws designed for nylon, where the transition zone is of proper length, have also been successful.

Breaker Plate and Screens

Screens (usually 80 - 100 mesh) are recommended for processing Celanex, Vandar, and Riteflex polyesters. Screens are used to protect the die from being damaged by foreign matter and to increase back pressure, especially when mixing fillers or pigments. A breaker plate, usually incorporated at the end of the screw, is used to support the screens.

Dies

Dies must be streamlined, having no areas where material can be trapped or hung up. Thermoplastic materials exposed to high temperatures for prolonged periods degrade and contaminate subsequent extruded product.

Processing Procedures

Final extrudate quality can be greatly affected by even small changes in the temperature of the melt. Generally speaking, the slower the extrusion rate (longer residence), the greater effect these changes will have. Therefore, a variable voltage (or proportioning) controller is best for keeping the melt thermally homogeneous.

Pressure changes during production indicate changes in viscosity and output rate of the melt. Diaphragm type transducers, which measure fluctuations in pressure, are recommended.

Startup

In starting up an empty machine, set temperature controllers for the die, adapter, and barrel using the appropriate temperatures provided in Tables 5.3 through 5.6. When they reach their operating temperatures, bring the remaining barrel temperatures up to the proper settings. After they have held the proper temperature for 20 - 30 minutes, turn the screw on at low RPM and start feeding polyester into the hopper. Carefully check both the ammeter and pressure gauges. As melt appears at the die, it may be hazy. At that time, temperature and head pressure should start to stabilize.

Purging and Shutdown

A machine should never be shut down while polyester remains in it. A medium-to-high density polyethylene should be used to purge the extruder. Temperature controllers should remain set at running conditions. Purge all of the polyester from the extruder. Continue running until all of the purge is out of the machine. Then shut down.

Table 5.3 Typical Extrusion Temperature Ranges for Celanex® Polyester

Parameters	Celanex Grades	
	1602Z, 2002, 2002-2, 2002-3, 2012-2, 2016, 3112-2, 3116	1600A, 1700A, 2001
Barrel Settings °C (°F)		
Zone 1	232 - 249 (450 - 480)	243 - 271 (470 - 520)
Zone 2	232 - 249 (450 - 480)	249 - 271 (480 - 520)
Zone 3	232 - 249 (450 - 480)	249 - 271 (480 - 520)
Zone 4	238 - 254 (460 - 490)	249 - 271 (480 - 520)
Zone 5	238 - 254 (460 - 490)	249 - 271 (480 - 520)
Adapter °C (°F)	238 - 254 (460 - 490)	249 - 271 (480 - 520)
Die °C (°F)	238 - 260 (460 - 500)	249 - 271 (480 - 520)
Melt Temperature °C (°F)	238 - 260 (460 - 500)	243 - 271 (470 - 520)

Table 5.4 Typical Extrusion Temperature Ranges for Vandar® Alloys

Parameters	Vandar Grades	
	2100, 2122, 2500, 4602Z, 8000, 8929, 9116	6000
Barrel Settings °C (°F)		
Zone 1	232 - 249 (450 - 480)	243 - 260 (470 - 500)
Zone 2	232 - 249 (450 - 480)	243 - 260 (470 - 500)
Zone 3	232 - 249 (450 - 480)	249 - 271 (480 - 520)
Zone 4	238 - 254 (460 - 490)	254 - 277 (490 - 530)
Zone 5	238 - 254 (460 - 490)	254 - 277 (490 - 530)
Adapter °C (°F)	238 - 254 (460 - 490)	254 - 277 (490 - 530)
Die °C (°F)	238 - 260 (460 - 500)	260 - 282 (500 - 540)
Melt Temperature °C (°F)	238 - 260 (460 - 500)	260 - 282 (500 - 540)

Table 5.5 Typical Extrusion Temperature Ranges for Impet® Polyester

Parameters	Impet Grades
	320R, 610R
Barrel Settings °C (°F)	
Zone 1	254 - 271 (490 - 520)
Zone 2	254 - 271 (490 - 520)
Zone 3	260 - 282 (500 - 540)
Zone 4	266 - 288 (510 - 550)
Zone 5	266 - 288 (510 - 550)
Adapter °C (°F)	266 - 288 (510 - 550)
Die °C (°F)	271 - 293 (520 - 560)
Melt Temperature °C (°F)	271 - 293 (520 - 560)

Table 5.6 Typical Extrusion Temperature Ranges for Riteflex Polyester Elastomer and Vandar 9118 and AB100

Parameters	All Riteflex Grades
Barrel Settings °C (°F)	
Zone 1	182 - 199 (360 - 390)
Zone 2	188 - 204 (370 - 400)
Zone 3	188 - 204 (370 - 400)
Zone 4	193 - 210 (380 - 410)
Zone 5	193 - 210 (380 - 410)
Adapter °C (°F)	193 - 210 (380 - 410)
Die °C (°F)	199 - 221 (390 - 430)
Melt Temperature °C (°F)	199 - 221 (390 - 430)

Wire Coating

In wire coating, the extruded tube of polyester forms a cone at the die, into which the wire passes. The wire is completely coated as it passes through the cross head.

The draw-down ratio is defined as the ratio between the cross-sectional area of the tube at the die face, to the cross-sectional area of the finished coating. Draw down ratio for polyesters should be between 6:1 and 10:1. See Figure 5.2.

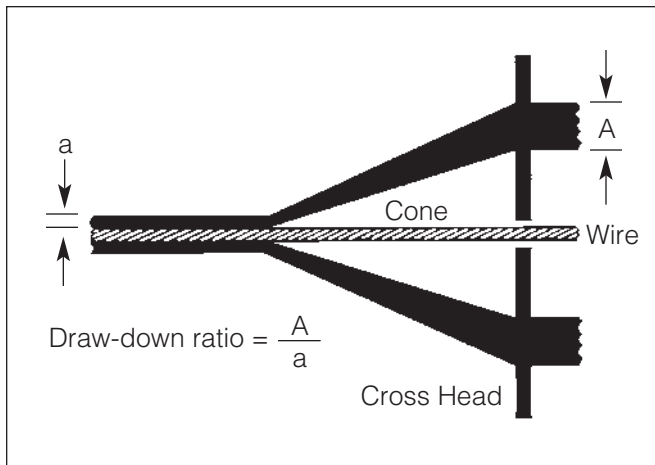


Figure 5.2 Polyester in Wire Coating

Since streamline design is critical to avoid degradation, the die face must have no areas where material can hang up. Cone length (the distance between the die face and the point where the polyester coats the wire) is very important. Generally speaking, it is between 1/2 and 2 inches, and is determined by trial-and-error. Too long a cone may sag and set before drawing is finished, while too short a cone can produce pinholes and tearing.

Before the coated wire enters the water cooling trough, it passes through an air cooling gap which is important in shrinking the coating on the wire. This governs adhesion of the insulation and should be balanced with the proper cone length to insure the desired integrity of the coating.

Cooling Trough

A water cooling trough is used to reduce the melt temperature and harden the coating. The water temperature in the trough is critical. Too low water temperatures of 4 - 16°C (40 - 60°F) will freeze the polyester coating into a semi-crystalline or amorphous state. Post crystallization of the polyester coating can occur and cause it to take a "set" on the spool or winding reel. A water temperature of 38 - 54°C (100 - 130°F) reduces post crystallization and eliminates or reduces spool-set, giving better mechanical properties.

Tube Extrusion

Polyester can be readily extruded into tubing up to 0.375 inch (9.5 mm) without requiring special equipment. Control of the polyester melt temperature is important. If too high, it can reduce the melt strength, causing irregular wall thickness. Too low a melt temperature can result in poor tube finish, uneven dimensions, and weld lines. Use the temperature ranges given in Tables 5.3 through 5.6 as starting points.

The same type of dies and temperature ranges used in wire coating are used in free extrusion of tubing. The extruded tube of resin is pulled through one or more sizing rings which are immersed in the water cooling trough (see Figure 5.3).

Vacuum Tank

A vacuum sizing tank is generally used for tubing 0.50 inch (12.7 mm) or larger. The vacuum in the water cooling trough causes the tube to expand to the sizing die set to the required outside tube dimensions. As before, melt and vacuum tank temperatures are most important because polyester is a semi-crystalline material with a relatively narrow melt-freeze range.

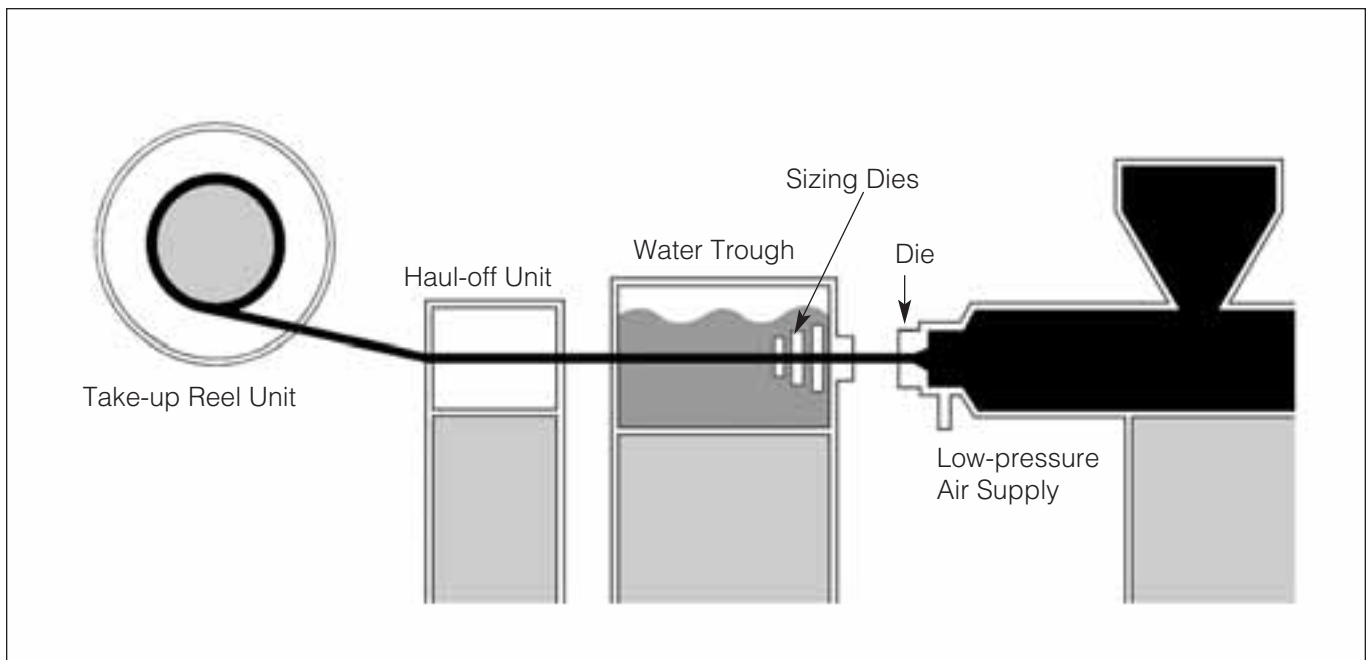


Figure 5.3 Polyester in Tube Extrusion

Sheet Extrusion

As shown in Figure 5.4, polyester sheeting is extruded with standard equipment including an extruder, a sheet die, a polishing roll stand, pull rolls, edge-trim knives, tension rolls, and a winder unit.

A flex lip coat hanger type die is best suited for sheet extrusion. Unlike the "T" type dies, it does not have stagnant areas that allow material to hang up and cause degradation. The flex lip must be adjusted to provide a uniform flow across the face of the die. Good temperature control across the die face is also necessary.

The air gap must be as small as possible and the melt bank (between the nip rolls) must also be very small. Too large a melt bank causes stress in the sheeting, while too small a melt bank results in nonuniform sheet thickness.

Polishing Roll Stand

Polishing rolls will improve the surface finish of the sheet. Normal temperatures of the rolls are as follows:

- Top Roll: 38 - 77°C (100 - 170°F)
- Center Roll: 38 - 71°C (100 - 160°F)
- Bottom Roll: 38 - 71°C (100 - 160°F)

Final roll temperatures and heat transfer are governed mainly by the internal cleanliness of these rollers.

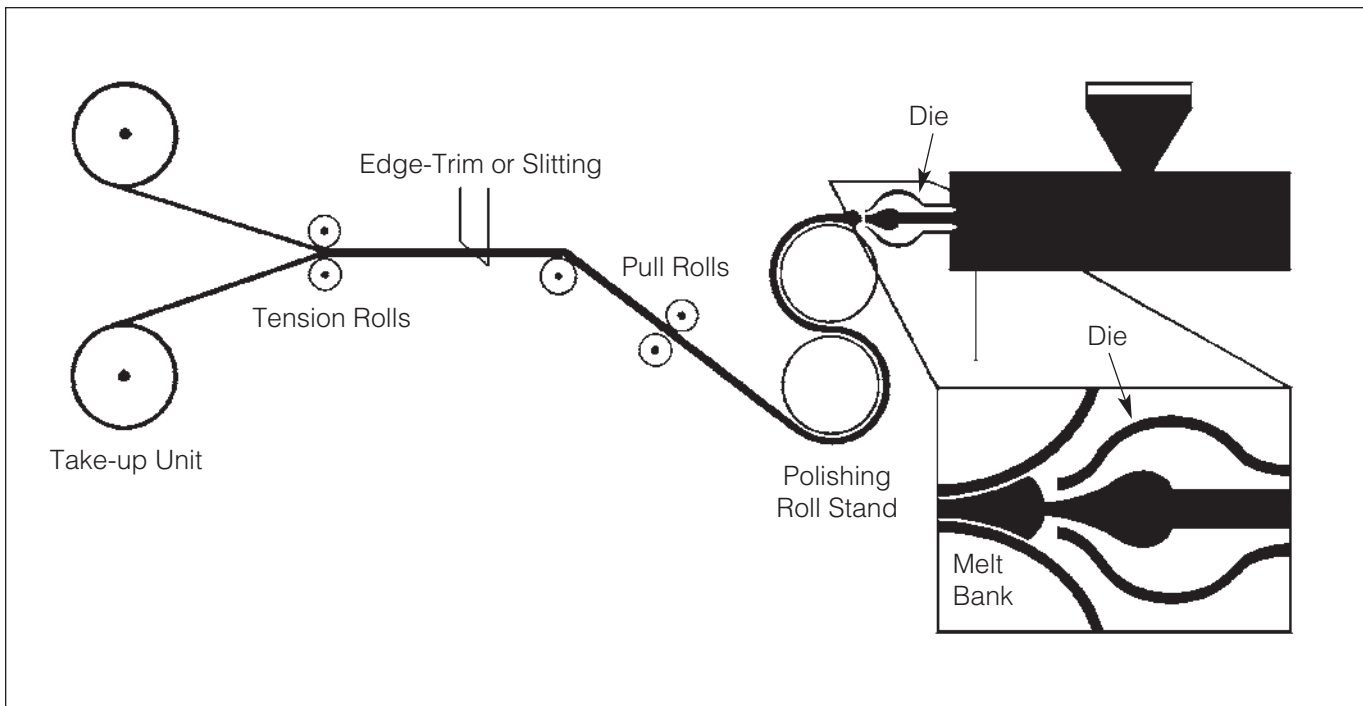


Figure 5.4 Polyester Sheet Extrusion

Troubleshooting – Extrusion

Troubleshooting

As with injection molding, many extrusion processing problems are caused by easily corrected conditions such as inadequate resin drying, incorrect temperatures, and/or pressures, etc.

Often, solutions to these problems can be found by following the recommendations in Table 6.1. Try them in the order in which they are listed under each problem category.

Table 6.1 Troubleshooting Guide - Extrusion Process

Problem	Typical Cause	Corrective Action	Celanex	Vandar	Impet	Riteflex
Blistering	Cooling too quickly.	Slow down cooling rate.	•	•	•	•
	Moisture in material.	Dry material to proper moisture level before use.	•	•	•	•
Bubbles	Trapped air.	Raise rear barrel temperature.				•
		Use correct screw.				•
		Use more back pressure.		•		•
		Check controllers.		•		•
	Degradation of resin due to high temperatures and/or long holdup time.	Lower temperatures.	•	•	•	•
		Increase extrusion rate.				•
		Use correct screw.	•	•	•	•
		Look for hang-ups in extruder and die.	•	•	•	•
	Check functioning of controller heaters and thermocouples.	•	•	•	•	
	Resin moisture content too high.	Dry material to proper moisture level before use.	•	•	•	•
Breaks, pin-holes, tears	Draw-down ratio too high.	Reduce draw-down ratio.	•	•	•	•
	Contamination.	See “Contaminated Extrudate”.	•	•	•	
	Short cone, too fast a draw.	Lengthen cone, reduce draw rate.	•		•	•
	Material temperature too low.	Raise melt or die temperature.	•	•	•	•
	Poor blends of pigments or fillers.	Blend more homogeneously before extrusion.	•	•	•	•
		Use correct screw.	•	•	•	•
		Reduce pigment or filter loading.	•	•		•
Coatings non-adherent	Cooling too fast.	Lengthen air gap.	•	•		•
		Slow down extrusion rate.	•	•		•
	Degradation of resin.	See “Bubbles”.	•	•	•	•
	Cone too long (cooling too soon before it coats).	Shorten cone.	•			•

Table 6.1 Troubleshooting Guide – Extrusion (Continued)

Problem	Typical Cause	Corrective Action	Celanex	Vandar	Impet	Riteflex
Contaminated extrudate	Poor handling of resin.	Protect resin, keep clean.	•	•	•	•
	Dirty extruder.	Remove all resins and clean.	•	•	•	•
	Extruder corrosion.	Use corrosion-resistant parts which contact melted resin.	•	•	•	•
	Dirty regrind.	Clean extruder.	•	•	•	•
Use clean regrind, dried to proper moisture level.		•	•	•	•	
Diameter fluctuates	Variation in take-off speed.	Check tension control.	•	•		•
		Raise pressure on tractor treads.	•	•		•
	Surging.	Raise screw speed.	•	•		•
		Raise back pressure with screen pack.	•	•		•
	Heat cycles.	Use variable transformers with time proportioning controllers. Make sure controllers are "ON" most of the time.	•	•	•	•
	Too slow a draw rate.	Reduce cone length.	•	•		•
	Too much tension on sizing plates (tube extrusion) or sizing die.	Shorten sizing die length by eliminating a plate or two.		•		•
		Use water or water and soap lubricant at sizing die.		•		•
	Uneven feed to extruder. Check uniformity of extrusion rate (cross head pressure).	Lower temperature at rear barrel.		•		•
		Cool throat of hopper.		•		•
	Moisture.	Dry material to proper moisture level before use.	•	•	•	•
	Out of round (deformed, nonconcentric)	Misshapen die.	Replace die.	•	•	
Correct guider tip.			•	•		•
Varying cooling rate.		Fix depth of water submersion.	•	•		•
		Center the die.	•	•		•
Coating sets after sagging.		Lower melt temperature.	•	•		•
		Step up rate of draw-down by increasing extruding speed, increasing draw-down ratio, or shortening cone length.	•	•		•
		Cool faster by reducing air gap from die to water trough or by raising output.	•	•		•
Take-up pressure too high.		Put slack in wire line.	•	•		•
		Lower capstan tension.	•	•		•
		Lengthen cooling so extrudate is set before take-up.	•	•		•

Table 6.1 Troubleshooting Guide – Extrusion (Continued)

Problem	Typical Cause	Corrective Action	Celanex	Vandar	Impet	Riteflex
Out of round (deformed, nonconcentric) Continued	Die off-center.	Center die.	•	•		•
	Guider tip too flexible.	Use shorter guider tip.	•	•		•
		Use bigger tip with same diameter hole.	•	•		•
	Hole in guider tip not small enough for wire diameter.	Use guider tip with smaller hole.	•	•		•
Out of round (buckling or folding)	Hang-up on die face or guider tip.	Remove imperfections.	•	•		•
	Melt tension varies.	Make hole in guider tip smaller or center the die.	•	•		•
	Too fast a draw rate .	Lengthen cone (reduce vacuum) for slower draw rate short cone).	•	•		•
	Draw-down ratio too high.	Reduce draw-down ratio.	•	•		•
	Compared with ratio of guider tip size to wire size, ratio of die size to coated wire size is too low.	Increase the draw ratio.	•	•		•
Extruder overloading	Feed section has too deep a flight depth.	Use screw with shallower feed.	•	•	•	•
		Use lubricant.	•	•	•	•
	Rear temperature too low.	Increase rear temperature.	•	•	•	•
		Check rear zone thermo-couple and controller.	•	•	•	•
	Wedging of pellets between flight land and barrel.	Raise rear temperature.	•	•	•	•
Shrink back	Wire stretching.	Reduce tension on wire.		•		•
	Orientation too great during draw-down.	Preheat the wire.		•		•
		Raise the draw rate (shorter cone).		•		•
		Reduce draw-down ratio.		•		•
		Enlarge air gap or lower quench rate.		•		•
Increase die and melt temperatures.		•		•		
Rough finish	Contamination.	See "Contaminated Extrudate".	•	•	•	•
	Dirty or poorly finished die.	Inspect finish on die and tip. Look for burrs and remove.	•	•	•	•
	Melt fracture caused by excessive shear.	Raise die temperature.	•	•	•	•
		Widen die opening.	•	•	•	•
		Lower extrusion rate.	•	•	•	•
		Increase melt temperature.	•	•	•	•
	Wrong rate of draw.	Change cone length.	•	•		•
	Material on die face.	Clean.	•	•	•	•
Wire vibrating.	Use dampening pads or guides.		•		•	

Table 6.1 Troubleshooting Guide – Extrusion (Continued)

Problem	Typical Cause	Corrective Action	Celanex	Vandar	Impet	Riteflex
Surging	Slipping drive belts.	Secure belts.	•	•	•	•
	Inadequate melt reservoir.	Use different screw to adjust.	•	•	•	•
		Slow down screw speed.		•		•
		Check temperature cycling.	•	•	•	•
		Make die opening smaller.	•	•		•
		Increase back pressure.	•	•	•	•
	Material bridging in feed section.	Check controller in feed zone.	•	•	•	•
		Reduce rear temperatures.	•	•	•	•
		Increase cooling in feed throat (water).	•	•	•	•
	Material bridging in transition section.	Change to screw with longer feed section.	•	•	•	•
		Raise temperature in rear zone.	•	•	•	•
Unmelted pellets or particles in extrudate	Barrel temperature too low.	Raise temperature settings.	•	•	•	•
	Compression ratio of screw too low.	Increase back pressure.	•	•	•	•
		Change screw.	•	•	•	•
	Watt density in heater too low.	Increase wattage.	•	•	•	•
		Change heater bands.	•	•	•	•
	Cold spots in extruder sections.	Get more heat to area along barrel extension to die neck.		•	•	•
		Check thermocouples and controllers for accuracy.	•	•	•	•
		Insulate exposed areas to prevent heat loss.	•	•	•	•
	Sheet sticking to roll	Roll too hot.	Reduce roll temperature.	•	•	•
Material too hot.		Reduce melt temperature.	•	•	•	•
		Inspect functioning of controller heaters and thermocouples.	•	•	•	•

World-Class Engineering Polymers

- **Celanex® thermoplastic polyester (PBT)**
- Celcon® and Hostaform® acetal copolymer (POM)
- Celstran® and Compel® long fiber reinforced thermoplastics (LFRT)
- Fortron® polyphenylene sulfide (PPS)
- GUR® ultra-high molecular weight polyethylene (UHMW-PE)
- Impet® thermoplastic polyester (PET)
- Riteflex® thermoplastic polyester elastomer (TPC-ET)
- Vandar® thermoplastic polyester alloy (PBT)
- Vectra® liquid crystal polymer (LCP)

NOTICE TO USERS: To the best of our knowledge, the information contained in this publication is accurate; however, we do not assume any liability whatsoever for the accuracy and completeness of such information. Any values shown are based on testing of laboratory test specimens and represent data that fall within the standard range of properties for natural material. Colorants or other additives may cause significant variations in data values. Any determination of the suitability of this material for any use contemplated by the users and the manner of such use is the sole responsibility of the users, who must assure themselves that the material subsequently processed meets the needs of their particular product or use, and part design for any use contemplated by the user is the sole responsibility of the user. The user must verify that the material, as subsequently processed, meets the requirements of the particular product or use. It is the sole responsibility of the users to investigate whether any existing patents are infringed by the use of the materials mentioned in this publication.

Please consult the nearest Ticona Sales Office, or call the numbers listed above for additional technical information. Call Customer Services for the appropriate Materials Safety Data Sheets (MSDS) before attempting to process our products. Ticona engineering polymers are not intended for use in medical or dental implants.

Except as otherwise noted, all of the trademarks referenced herein are owned by Ticona or its affiliates. Fortron is a registered trademark of Fortron Industries LLC.

Contact Information

Americas

Ticona Engineering Polymers
Product Information Service
8040 Dixie Highway
Florence, KY 41042
USA
Tel.: +1-800-833-4882
Tel.: +1-859-372-3244

Customer Service

Tel.: +1-800-526-4960
Tel.: +1-859-372-3214
Fax: +1-859-372-3125

email: prodinfo@ticona.com

Europe

Ticona GmbH
Information Service
Professor-Staudinger-Straße
65451 Kelsterbach
Germany
Tel.: +49 (0)180-584 2662 (Germany)*
+49 (0)69-305 16299 (Europe)**
Fax: +49 (0)180-202 1202

See example below for rate information:

* 0.14 €/min + local landline rates
**0.06 €/call + local landline rates

email: infoservice@ticona.de

Ticona on the web: www.ticona.com

Asia

Celanese (China) Holding Co., Ltd.
3F, China Development Bank Tower
500 South Pu Dong Road
Shanghai, 200120
P.R. China

Customer Service

Tel.: +86-21-3861 9266
Fax: +86-21-3861 9599

email: infohelp@ticona.com

www.ticona.cn